



UNIVERSITÀ DEGLI STUDI  
DI TRENTO

---

DEPARTMENT INFORMATION  
ENGINEERING AND COMPUTER SCIENCE  
MASTER DEGREE IN COMPUTER SCIENCE

MASTER THESIS

**Goal Models Vs Five Forces Models:  
A Comparative Study of Strategic  
Analyses**

*Author:*  
Joseph Brian Musanje.  
KASOZI

*Supervisor(s):*  
Prof. John Mylopoulos  
Dr. Elda Paja  
Dr. Alejandro Mate

ACADEMIC YEAR 2014-2015

---



---

# ABSTRACT

---

The performance of an enterprise is determined by its strategic objectives, and the strategic plan it adopts through some form of strategic analysis in order to meet these objectives. However, strategic analysis is currently only supported through unsystematic and informal processes such as SWOT analysis and the Five Forces Model. This thesis proposes conceptual goal modeling as a systematic approach to strategic analysis and shows through a comparative study how this analysis can be conducted for a Goal Model and the Five Forces Model. The study is conducted through a case study adopted from the literature.



---

# ACKNOWLEDGEMENT

---

Special gratitude I give to my supervisor Prof. John Mylopoulos and Co-supervisors Dr. Elda Paja and Dr. Alejandro Mate whose contribution in stimulating suggestions and encouragement, helped me to coordinate the entire study especially in developing the models performing the analysis and writing this report. Finally i would like to thank my family and all friends who supported me in various ways during my research

---

# Contents

---

<b>Contents</b>	<b>4</b>
<b>1 Introduction</b>	<b>7</b>
1.1 Motivating example . . . . .	8
1.2 Problem Statement . . . . .	9
1.3 Objectives . . . . .	9
1.4 Contribution . . . . .	10
1.5 Methodology . . . . .	11
1.6 Organisation of the thesis . . . . .	11
<b>2 Related Works</b>	<b>13</b>
2.1 SWOT Analysis . . . . .	13
2.2 Cost Benefit Analysis ,(CBA) . . . . .	15
2.3 Balanced score cards . . . . .	16
2.4 Decision trees, Probability distributions and influence diagrams . .	17
2.5 PESTLE . . . . .	23
2.6 MOST . . . . .	23
2.7 CATWOE . . . . .	24
2.8 Conclusion . . . . .	24
<b>3 Baseline</b>	<b>27</b>
3.1 Goal-Oriented Requirement Engineering <b>GORE</b> . . . . .	27
3.1.1 Istar Framework . . . . .	28
3.1.2 Business intelligence models (BIM) . . . . .	30
3.1.3 Strategic Goal Evaluation . . . . .	34
3.2 FFM of competition . . . . .	34
3.3 Uncertainty model . . . . .	35
<b>4 Case Study</b>	<b>37</b>
4.1 Case Study Description . . . . .	37

4.2	Methodology . . . . .	38
4.3	Modelling Decisions . . . . .	38
4.3.1	RCCL Strategic Goal Model . . . . .	38
4.3.2	Business Intelligence Models (BIM) . . . . .	46
4.3.3	Porter's Five Force model . . . . .	54
4.3.4	Relationship Between FFM and RCCL goal models . . . . .	58
<b>5</b>	<b>Evaluation and Results</b>	<b>59</b>
5.1	Goal modelling and analysis . . . . .	59
5.1.1	Dependency model . . . . .	60
5.1.2	Qualitative Reasoning with Goal Models . . . . .	62
5.2	FFM . . . . .	67
5.2.1	How FFM works . . . . .	69
5.3	Comparison between Goal model analysis and FFM . . . . .	70
5.4	Complementarity between FFM and Strategic goal models . . . . .	71
5.5	Systematic Decision making using Goal analysis . . . . .	71
5.6	Conclusion . . . . .	72
<b>6</b>	<b>Conclusion and Future work</b>	<b>73</b>
	<b>Bibliography</b>	<b>75</b>
	<b>A Relationship Between FFM and RCCL</b>	<b>79</b>
	<b>List of Figures</b>	<b>81</b>
	<b>List of Tables</b>	<b>82</b>





# Chapter 1

---

## Introduction

---

Business analytics (BA) consists of concepts, techniques, tools, technologies, systems, methodologies and applications that analyze critical business data to help an enterprise better understand its business and market and make timely business decisions [30]. In the past decade, BA has emerged as an important area of study for both practitioners and researchers, reflecting the magnitude and impact of data and decision related problems to be solved in contemporary business organisations. Despite the existence of BA, decision making activities often occur in a cloud of uncertainty where there is no clear-cut way to develop or choose among alternatives.

Decision making in companies is currently supported by analysis techniques such as cost-benefit analysis where decision is made based on how much the company benefits in terms of profits (economic values)[38] but the weakness is that companies don't only have economic objectives which are ignored when analysis is conducted only in terms of economic values. Other models like SWOT analysis[28] enable decision makers to determine their weaknesses, strengthen, threats and opportunities but it does not show how they can pursue the opportunities or how they could build on the strength to overcome threats and weaknesses.

The economic models here are able to determine what the company has but they aren't able to predict how the company can get better and what strategy could be used. Hence there is a gap between analysis techniques and the decision making process. Although there different business models (analytics techniques and business intelligence tools), managers are not able to make effective decisions because they still miss a systematic approach on how to choose among alternatives.

Considering some examples where decision makers made wrong decisions. Sony's consumer electronics business long dominated the TV space with its cathode ray tube technology (CRT). However due to its success in this business, it was slow

to move to promoting flat screen technology, even though it was one of the first to develop the LED flat screen. Instead it wanted to capitalize on its investment in the CRT technology rather than invest in the new technology to meet emerging consumer trends. By trying to hold onto the old technology and garner as much profit as possible before moving to the new technology, they lost their lead to Samsung, a company who, not held back by a large CRT business, saw an opening to gain market share as Sony lagged behind [20]. If Sony had a systematic approach to decision making, it would have predicted what might happen to the market following a given decision.

[7] describes other numerous executive-level decision-making failures revolving around major corporate mergers and acquisitions. Over 25 years examined, they document hundreds of failed mergers and acquisition decisions that resulted in \$380 billion in write-offs and the wholesale destruction of shareholder value.

For the long-term sustainability of any company, it is the business analysis process that matters most. Good people and an abundance of capital are great resources to have, but the way an organization decides on its goals, decides on how to conduct routine business, and decides how to handle any unusual challenges that may confront it, and, as a result, obtains its results in any particular period of time dramatically impacts its sustainability. Decision making processes must not only support the attainment of goals, but also must reflect the means by which decisions are made, executed, and results achieved. So the “how” is perhaps just as important as the “what. Therefore there is need for a more systematic decision making process which highlights what strategic alternative will provide results where the output exceeds the cost of inputs.

## 1.1 Motivating example

Here we introduce a running scenario [16] where Tom Murphy the Royal Caribbean Cruises Limited (RCCL) CIO faces a challenge of making decision on which alternative he should consider to integrate Information Technology in company processes while preserving the company objectives. RCCL is a leisure cruise company aiming at being competitive in the leisure cruise business by increasing revenue, lowering costs and enhancing customer experience. Murphy proposed an IT plan so as to realise the company objectives but he faced a challenge of how to implement this plan without hurting the company objective.

Murphy is considering three main alternatives namely:

- (a) To do nothing beyond the current expenditure levels
- (b) To make an additional eight million on infrastructure investments in the next twelve months to untangle the seven reservation systems as a step to

rapidly developing a single reservation system

- (c) To introduce even changes more quickly by setting a much higher budget than the 8 million.

Keeping in mind company objectives, Murphy has to implement a strategy that will align with these objectives. Using existing economic models like SWOT, Murphy can determine threats, opportunities, strength and weakness of the company but can't determine which alternative to implement. This applies to other models like cost benefit analysis where he will be able to determine how much the company will earn or spend but this ignores non-monetary objectives like enhancing customer experience. Therefore Murphy needs a more systematic decision making process from which he can determine which alternative can be implemented to achieve optimum results that align with company objectives.

## 1.2 Problem Statement

Decision making is a very important process in any business, Currently, this process is supported by a number of economic models, including cost-benefit analysis and SWOT (strengths, weaknesses, opportunities, threats) analysis. These economic models answer questions, how much does/will the company earn, what the company will have to spend but they ignore important questions. such as whether the company will survive in market, or what is the best alternative to yield optimum results. The impact of ignoring such questions is seen to negatively impact all businesses from the simple start-up to multi-million companies. Decision is defined as a determination arrived at after consideration [31] but with the economic models, there is no determination arrived at but rather only considerations of the different company qualities. Therefore this work tries to address the gap between determination and consideration hence providing a systematic approach to decision making. We describe how conceptual modelling and analysis can be used as a systematic approach to decision making process by comparing goal model analysis with the Five Forces Model (FFM).

## 1.3 Objectives

The main objective of this study is to show how conceptual modelling and analysis can provide effective tools for decision making. We compare strategic goal models (analysis) [32, 43, 13] with Porter's FFM of competition[35] in order to determine the strategy that will bring optimum results to a company in our case the RCCL. We introduce FFM, goal modelling and BIM. BIM supports strategic goal reasoning[26] which considers the influences among enterprise internal, external situations, indicators and strategic goals. But according to Porter's framework,

an enterprise is influenced by FFM[36]. As part of the study we develop and evaluate the FFM reasoning technique and using BIM reasoning on the model. In order to enable business managers or decision makers to understand the context in which the firm operates. This reasoning will provide business users the capability to determine how a selected strategy performs relative to the following five forces in relation to the enterprise strategic goal.

- **Customer bargaining power**, this is the impact the buyers have on an enterprise.
- **Supplier bargaining power**,the enterprise needs raw materials to produce its goods and services; it's the supplier who supplies these raw materials to an enterprise creating a buyer-supplier relationship. If there are many suppliers, the impact on the prices of raw materials will be in favour of the enterprise and conversely otherwise.
- **Threat of substitution**,if there are available alternatives then the threat of substitution increases. Other questions that can be considered are:
  - (a) How easy is it to find alternatives
  - (b) Can the service be automated.
- **Threat of new entrants**,if a new business can be easily started up in a given sector without substantial investment, then this is a threat. For example the Internet has made this a reality in many sectors, especially publishing. Therefore decision makers should answer questions like how easy is it to start up in this business, what are the rules and regulations, what finance would be needed to start-up, are there barriers to entry which give you greater power.
- **Competitive rivalry**,what is the competition level in the sector, what is the competitor situation. Markets where there few competitors are attractive but can be short lived. The intensity of competitive rivalry most times is the major determinant of competitiveness.

## 1.4 Contribution

This thesis contributes to the area of business analytics. Specifically, it describes how conceptual modelling and analysis can provide systematic decision making process by introducing and studying the complementarity between strategic goal analysis and FFM analysis.

## 1.5 Methodology

By applying i\*[32] modelling, in this thesis we identified and described the performance of goal models on strategic business decision making, using the RCCL case study. While reasoning with goal models we used qualitative reasoning but this didn't yield satisfactory results. Accordingly, we did a more detailed form of analysis by introducing control variables on influence links where each link contributed a given percentage (represented by the control variable) on the satisfaction of the destination goal. Control variable were determined both by asking "What -if" and from provided information in the case study.

The goal model analysis resulted into two alternatives the company could choose from. To be more specific, we improved the results by reasoning over the business intelligence model. This involved adding some other concepts that are missing in the goal model namely; situation, domain assumption and indicator. We were able to reason considering both the business external and internal environments. In order to make satisfactory decision we introduced the FFM in BIM and reasoned on how the five forces are affected by any of the alternatives or strategies taken by the RCCL. This was very important because it provided more concrete evidence to decision makers that the chosen alternative will satisfy the company main goal as well as keeping the company competitive in the market. The modelling process is described in the following sections.

## 1.6 Organisation of the thesis

The thesis is structured in to six Chapters. Chapter 1 introduces and motivates the research and gives a general overview of the study. Chapter 2 describes already existing literature related to the study while Chapter 3 details the research baseline. Chapter 4 describes the case study. Chapter 5 details the research contribution and outcomes. Finally, Chapter 6 concludes and suggests directions for future research.



## Chapter 2

---

# Related Works

---

Business modeling, business analytics, and strategic decision making are broad areas of research thus have been widely investigated in the literature and studied or applied in multiple disciplines like business planning, requirements engineering and business intelligence. This chapter presents a theoretical framework and definitions which are relevant to this research. It also provides a detailed literature review of the theories, concepts and other existing economic models relevant to the thesis.

### 2.1 SWOT Analysis

SWOT analysis is one of the most popular business analysis techniques [14] as well as many other disciplines involved with strategic planning [29]. SWOT analysis was first introduced by Stanford University's Albert Humphrey in the 1960's. It outlines the strategic strengths, weaknesses, opportunities, and threats to determine an organization's competencies as well as identify future opportunities. SWOT analysis is a framework that links the firm's capabilities to its relevant competitive environment. SWOT analysis focuses on evaluating the strategic position of a firm by analysing the strengths, weaknesses, opportunities and threats [28]. Thus it summarizes the key issues from the business environment and the strategic capability of an organization that are most likely to impact on strategy development.

The strengths are those points where a company has a competitive advance in comparison with their competitors. The weaknesses of a company are those points where the company has a competitive demerit in comparison with their competitors. The opportunities and threats of a company consist of external influences that may help the company achieve its objectives while threats are characteristics of the external environment that may prevent the organization from achieving

its strategic goals [10] SWOT was designed such that the competitive strategy of the company can fit in the analysis.

This kind of analysis is used by an organization to define the situation they are currently in, or likely to be in within the near future. As a type of situational analysis, SWOT is the acronym for the analytic technique that assesses the Strengths, Weaknesses, Opportunities, and Threats of a situation. The basic assumption of the analysis is: "a company must align internal activities (Strengths and Weaknesses) with external realities (Opportunities and Threats)" to successfully produce results that can help create a competitive strategy.[42]

### **Strengths**

Strengths are the qualities that enable accomplishment of the organization's objectives. These are the basis on which continued success can be made and sustained. Strengths can be either tangible or intangible. Strengths are the beneficial aspects of the organization or the capabilities of an organization, which includes human competencies, process capabilities, financial resources, products and services, customer goodwill and brand loyalty. Examples of organizational strengths are huge financial resources, broad product line, no debt, committed employees, etc.

### **Weaknesses**

Weaknesses are the qualities that prevent the accomplishment of the company's objectives and achieving its full potential. These weaknesses deteriorate influences on the organizational success and growth. They must be minimized and eliminated

### **Opportunities**

Opportunities are presented by the environment within which the organization operates. These arise when an organization can take benefit of conditions in its environment to plan and execute strategies that enable it to become more profitable.

### **Threats**

Threats arise when conditions in external environment jeopardize the reliability and profitability of the organization's business. They compound the vulnerability when they relate to the weaknesses. Threats are uncontrollable. When a threat comes, the stability and survival can be at stake.

After completing the SWOT analysis, the firm should decide how to turn weaknesses into strengths and threats into opportunities[28], or how to deal with the threats and capitalize on the opportunities through its strengths and weaknesses [17]. SWOT analysis is not always the best technique to utilize in strategic planning and some [3, 40] have shown that SWOT harms performance however, it is a versatile technique that can easily be utilized in conjunction with other analytic techniques.



## 2.2 Cost Benefit Analysis ,(CBA)

Cost-benefit analysis is very widely used and it is therefore important that its methods be properly understood. The purpose of cost-benefit analysis is to provide a consistent procedure for evaluating decisions in terms of their consequences. The main difference between cost-benefit analysis and other methods of economic evaluation that were discussed earlier and will be discussed later in this section is that it seeks to place monetary values on both the inputs (costs) and outcomes. As such, a major advantage of cost-benefit analysis lies in forcing decision makers to explicitly and systematically consider the various factors which should influence strategic choice (benefits)[38, 6]

CBA adds up the total costs of a programme or activity and compares it against its total benefits therefore decisions are made by comparing the net present value (NPV) of the programme or project's costs with the net present value of its benefits. Decisions are based on whether there is a net benefit or cost to the approach, i.e. total benefits less total costs. Costs and benefits that occur in the future have less weight attached to them in a cost-benefit analysis[15]

### How to use CBA

#### Step one:

Brainstorm Costs and Benefits

This involves identifying the costs and benefits that might be involved with a given strategy. The decision makers have to brainstorm and agree on the expected input and output.

#### Step two:

Assign a Monetary Value to the Costs

The second step is to assign monetary value to the identified costs. Costs include the costs of physical resources needed, as well as the cost of the human effort involved in all phases of a project. Costs are often relatively easy to estimate (compared with revenues). The problem here is that the additional costs that might be incurred during the project or strategy may be ignored.

#### Step three:

Assign a Monetary Value to the Benefits

#### Step four:

Compare Costs and Benefits

The last step is to compare the value of costs to the value of benefits, and use this analysis to decide which strategy is better for the company. This is done by computing both the total costs and benefits and then compares which of them outweighs the other on any given strategy. At this stage it's important to consider the payback time, to find out how long it will take for to reach the break-even point

However the CBA comes with a list of problems as stated by Frank Ackerman in his paper published in 2008 and these include [27];

- Pricing the priceless. It's not true that every cost can be converted into monetary value
- Troubling trade-offs. Closely related to the problem of priceless values is the hidden assumption that everything can be traded for everything else.
- Uncertainty and precaution Cost-benefit analysis requires definite numbers on each side of the balance sheet, to allow the comparison of costs and benefits. Many important questions of environmental policy, however, involve inescapably uncertain outcomes
- Exaggerated costs the cost side of the cost-benefit comparison poses fewer problems than the benefit side, because many of the costs are naturally expressed in monetary terms. Yet even here there are pitfalls in the standard methods

## 2.3 Balanced score cards

The balanced scorecard is a strategic planning and management system that is used extensively in business and industry, government, and non-profit organizations worldwide to align business activities to the vision and strategy of the organization, improve internal and external communications, and monitor organization performance against strategic goals. The balanced scorecard has evolved from its early use as a simple performance measurement framework to a full strategic planning and management system. The "new" balanced scorecard transforms an organization's strategic plan from an attractive but passive document into the "marching orders" for the organization on a daily basis. It provides a framework that not only provides performance measurements, but helps planners identify what should be done and measured. It enables executives to truly execute their strategies [4]

The balanced scorecard suggests that we view the organization from four perspectives, and to develop metrics, collect data and analyse it relative to each of these perspectives:

### **The Learning & Growth Perspective**

This perspective includes employee training and corporate cultural attitudes related to both individual and corporate self-improvement.

### **The Business Process Perspective**

This perspective refers to internal business processes. Metrics based on this perspective allow the managers to know how well their business is running, and whether its products and services conform to customer requirements

### **The Customer Perspective**

Recent management philosophy has shown an increasing realization of the importance of customer focus and customer satisfaction in any business. These are leading indicators: if customers are not satisfied, they will eventually find other suppliers that will meet their needs. Poor performance from this perspective is thus a leading indicator of future decline, even though the current financial picture may look good. In developing metrics for satisfaction, customers should be analysed in terms of kinds of customers and the kinds of processes for which we are providing a product or service to those customer groups.

**The Financial Perspective**, Kaplan and Norton do not disregard the traditional need for financial data. Timely and accurate funding data will always be a priority, and managers will do whatever necessary to provide it. In fact, often there is more than enough handling and processing of financial data.

Many international research projects have shown that Balanced Scorecard concept is a very popular tool around the world. At the same time together with numerous success stories there have been also several cases where the project implementation is not finalised at all. Therefore Kanji noted [19]:

- Balanced Scorecard is only a conceptual model and it is very difficult to elaborate this based on the methodology provided by Kaplan and Norton without previous thorough practical experience;
- The focus of traditional Balanced Scorecard tends to be too much on lagging indicators that show final results only. Many of the measurement systems, such as European Foundation for Quality Management are more balanced and provide equal attention to leading and lagging indicators;

## **2.4 Decision trees, Probability distributions and influence diagrams**

An influence diagram is an intuitive visual display of a decision problem. It depicts the key elements, including decisions, uncertainties, and objectives as nodes



Figure 2.1: A diagram showing Balanced Scorecard board.

of various shape and colours. It shows influences among them as arrows as illustrated in figure 2.2. This simple influence diagram depicts a variable describing the situation, a decision "What do we do?", a chance variable "What's the outcome?", and final valuation "How do we like it?". These four node types are the building blocks of decision problems. The influence diagram gives a high-level conceptual view on which a detailed quantitative model can be built.

### Influence Diagram concepts

A **decision**(what do we do?) is a variable that (organization) decision maker have the power to modify directly. It could be whether to invest in a new project, how much to invest, how much to bid, where to locate a new site.

A **chance variable**(what's the outcome) is an uncertain quantity, whose value decision makers don't (yet) know, because they don't have complete information

or maybe it's in the future and which (unlike a decision) they cannot control directly.

An **objective**(how do we like it) is a measure of satisfaction with possible outcomes. It might be net present value, lives saved, or more generally, "utility". Usually, the decision maker is trying to find decisions to maximize (or minimize) the objective. Often an objective combines multiple sub-objectives or attributes, which may be in conflict such as energy costs, and environmental and health risks. Usually, when the objective is uncertain, decision analysts suggest maximizing the expected value, or more generally expected utility, based on risk preference.

A **general variable**(what's the situation) is a deterministic function of the quantities it depends on.

An **arrow** denotes an influence. An arrow from A to B means that that knowing A would directly affect our belief or expectation about the value of B. An influence expresses knowledge about relevance. It may, but need not, imply a causal relation, or a flow of material, information, or money.

An influence diagram is at once both a formal description of the problem that

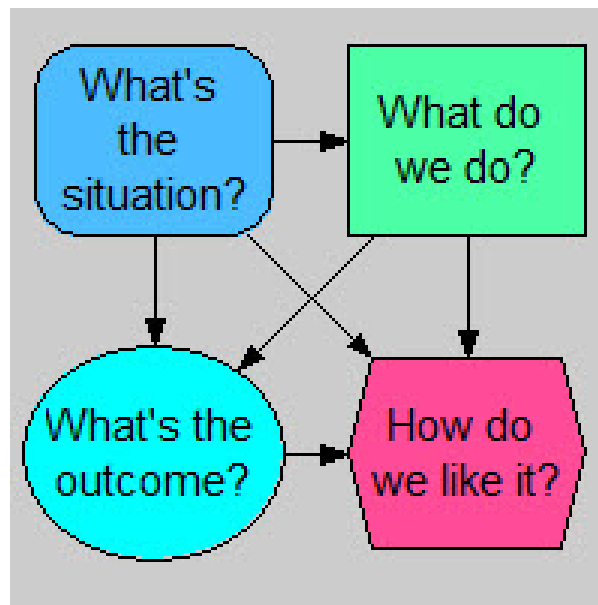

Figure 2.2: Simple Influence Diagram

can be treated by computers and a representation easily understood by people in all walks of life and degrees of technical proficiency. It thus forms a bridge between qualitative description and quantitative specification[25].

Influence diagram serve at three levels of specification of relation i.e. function, and number, and in both deterministic and probabilistic cases.

In the **deterministic case**, relation means that one variable can depend in a general way on several others.

In the **probabilistic case**, at the level of relation we mean that given the information available, one variable is probabilistically dependent on certain other variables and probabilistically independent of still other variables.

At the level of **function**, the probability distribution of each variable is assigned and conditioned on values of the variables on which it depends.

At the level of **number**, unconditional distributions are assigned on all variables that do not depend on any other variable and hence determine all joint and marginal probability distributions. It should be noted that because of its generality, the influence diagram is an important tool not only for decision analysis, but for any formal description of relationship and thus for all modelling work [11]. Thus in this research, the idea of influence diagram was borrowed while modeling both the company model and FFM

### Probabilistic Dependence

A probabilistic dependency arises as a result of uncertainty. This is One of the most perplexing aspects of making decisions under uncertainty is the problem of representing and encoding probabilistic dependencies.

### Probabilistic Independence

Probabilistic independence, like the assigning of probability itself, depends on the state of information possessed by the assessor. If  $\mathbf{x}$ ,  $\mathbf{y}$ , and  $\mathbf{z}$  be state variables of interest, which can be either continuous or discrete. Then  $\mathbf{x}|\mathbf{S}$  is the probability distribution assigned to  $x$  given the state of information  $\mathbf{S}$ . Two variables  $\mathbf{x}$  and  $\mathbf{y}$  are probabilistically independent given the state of information  $\mathbf{S}$  if:

$$x, y | S = x | S, y | S \quad (2.1)$$

Or equivalently  
If

$$x | y, S = x | S \quad (2.2)$$

### Expansion

Regardless of whether  $x$  and  $y$  are probabilistically independent, we can write

$$x, y | S = x | y, S y | S = y | x, S x | S \quad (2.3)$$

We call this the “chain rule of probabilities.” Note that for three events there are six possible representations.

$$\begin{aligned}
 \{x, y, z \mid S\} &= \{x \mid y, z, S\}\{y \mid z, S\}\{z \mid S\} \\
 &= \{x \mid yz, S\}\{z \mid y, S\}\{y \mid S\} \\
 &= \{y \mid x, z, S\}\{x \mid z, S\}\{z \mid S\} \\
 &= \{y \mid x, z, S\}\{z \mid x, S\}\{x \mid S\} \\
 &= \{z \mid x, y, S\}\{x \mid y, S\}\{y \mid S\} \\
 &= \{z \mid x, y, S\}\{y \mid x, S\}\{x \mid S\}
 \end{aligned}$$

Therefore For n variables there are n! Possible expansions, each requiring the assignment of a different set of probabilities and each logically equivalent to the rest. However, while the assessments are logically equivalent, there may be considerable differences in the ease with which the decision maker can provide them. Thus, the question of which expansion to use in a problem is far from trivial [25].

**Probability Trees**

Associated with each expansion is a probability tree which is a succession of

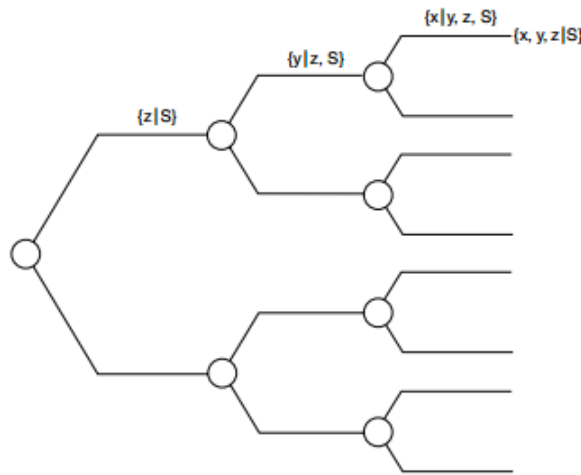

Figure 2.3: A diagram showing probability tree(Decision tree).

nodes with branches emanating from each node to represent different possible values of a variable. The expansion

$$\{x, y, z \mid S\} = \{x \mid y, z, S\}\{y, z \mid S\}\{z\} \tag{2.4}$$

The first assignment made is the probability of various values of z. The probability of each value of y is assigned conditioned on a particular value of z, and placed on the portion of the tree indicated by that value. Finally, the probabilities of various levels of x are assessed given particular values of z and y and placed on the portion of the tree specified by those values. When this has been done for all

possible values of

$$x, y, z$$

the tree is complete. The probability of any particular path through the tree is obtained by multiplying the values along the branches and is

$$\{x, y, z \mid S\}$$

A variable is controlled by a decision maker is represented in a tree by a decision node. But major problem with decision trees arises from the first of these characteristics. The order of expansion required by the decision tree is rarely the natural order in which to assess the decision maker's information. The decision-tree order is the simplest form for assessment only when each variable is probabilistically dependent on all preceding aleatory and decision variables.

### **Strengths and Weaknesses of the Decision Tree Representation**

The strengths of the decision tree representation method are its simplicity and its flexibility. Decision trees are based on the semantics of scenarios. Each path in a decision tree from the root to a leaf represents a scenario. These semantics are very intuitive, flexible and easy to understand.

The weaknesses of the decision tree representation method are its modeling of uncertainty, its modeling of information constraints, and its combinatorial explosiveness in problems in which there are many variables. Since decision trees are based on the semantics of scenarios, the placement of a random variable in the tree depends on the point in time when the true value of the random variable is revealed. Also, the decision tree representation method demands a probability distribution for each random variable conditioned on the past decisions and events leading to the random variable in the tree [39].

### **Strengths and Weaknesses of the Influence Diagram Representation.**

The strengths of the influence diagram representation are its intuitiveness and its compactness. Influence diagrams are based on the semantics of conditional independence. Conditional independence is represented in influence diagrams by d-separation of variables [34]. Practitioners who have used influence diagrams in their practice claim that it is a powerful tool for communication, elicitation, and detailed representation of human knowledge [33, 24]. Influence diagrams do not depict scenarios explicitly. They assume symmetry (i.e. every scenario consists of the same sequence of variables) and depict only the variables and the sequence up to a partial order. Therefore, influence diagrams are compact and computationally more tractable than decision trees. The weaknesses of the influence diagram representation are its modeling of uncertainty and requirement of symmetry. Influence diagrams demand a conditional probability distribution for each random variable.



## 2.5 PESTLE

PESTLE technique is a business analytics tools which is meant to scrutinize the various external elements which can affect an enterprise and its operations. It is made up of six characteristics [1].

### **Political**

Politics plays an important role in any business. This is because there is a balance between systems of control and enterprises. This analysis focuses on the present and future political influences to the enterprises.

### **Economic**

This considers metrics that measure the health of any economic region i.e. global, national and local

### **Sociological**

Social factors assess the mentality of the individuals or consumers in a given market. These are also known as demographic factors.

### **Technological**

This step entails recognizing the potential technologies that are available and how their effect on the business or enterprise market position.

### **Legal**(effect of national and world legislation)

This factor examines the impact of the legal arm at all levels (national and world legislation).So it involves learning and understand the laws that might have any impact on the business.

### **Environmental**(issues on local, national and world environment)

Consumers and governments blame industries for harming the environment. Therefore Governments levy huge taxes and fines upon companies for polluting. But also companies are rewarded for the positive impact on the environment. It's assumed that consumers are willing to switch from the companies that ignore their environment duties.

A PESTLE analysis is often used as a generic 'orientation' tool, finding out where an organisation or product is in the context of what is happening outside that will at some point affect what is happening inside an organisation. The six elements form a framework for reviewing a situation, and can also be used to review a strategy or position, direction of a company, a marketing proposition, or idea. Compared with The conceptual modeling, PESTEL ideally gives the overall view of the business environment and some factors may not be applicable to some business environments.

## 2.6 MOST

This is a simple framework for analysing what the organisation does. MOST stands for mission, objectives, strategy and tactics.

**Mission** This answers the question “What do you do?” and always is framed in terms of the benefits and stakeholders.

**Objectives** These translate the company’s mission into overall intent that drives the strategy process.

**Strategy** This includes the high-level decisions that shape what is done and how it is done

**Tactics** Tactical planning takes strategic decisions and figures out how to implement them in practice. Therefore Tactics are the methods used to carry out your strategies.

## 2.7 CATWOE

The CATWOE focuses on defining necessary elements that together constitute a human activity system from a certain perspective. CATWOE stands for Customer, Actor, Transformation, Weltanschauung, Owner, and Environmental constraints. This kind of analysis has a central role in modelling in that it brings forth various perspectives on a problem situation as well as questioning the assumptions used. CATWOE is usually used to enrich both the Root Definition and the Conceptual Model, but it can also be seen as a technique for evaluating the completeness of Root Definitions (mission) and Conceptual Models [8, 43].

### **Transformation, T**

represents the purposeful activity to be modelled, expressed as a Transformation process. Traditionally, T has been formulated as transformation of some input to some output. [5] This formulation encourages the modeller to make links between the current situation (input) and the imagined future situation (output). Setting the current and imagined situations side by side help to make explicit whether the Transformation is likely to be minor, radical, or impossible

**Weltanschauung, W** is related to the individual’s worldview and beliefs and explains what makes T meaningful. [5]

**Customer, C** is defined as the beneficiary or victim of the system’s activity.

**Owner, O** Owner of the system, is defined as those who could stop the **T**.

**Actor, A** is defined as those who would do **T**.

**Environment, E** Environmental constraints, refers to “elements outside the system which it takes as given in [10]. Common E’s prove to be; time and resources, existing structure, ethos, norms, modern technology, company resources, corporate objectives, and project definition.[5]

## 2.8 Conclusion

This section has described some of the existing works, literatures and techniques used for strategic decision making. But each of the Identified technique has loop

back which might cause the company to lose a lot of income or even its market. The theoretical assumptions from these techniques may not partially apply to the business environment. In real-life business situations, decisions can often fail because best alternatives are not clear at the outset, or key factors are not considered as part of the process. To stop this from happening, decision makers need to bring problem-solving and decision-making strategies together to clarify their understanding. A logical and ordered process can help to do this by making sure that it address's all of the critical elements needed for a successful outcome. This proposed process is described in section 5 and 4



## Chapter 3

---

# Baseline

---

The baseline of this work includes business modeling \* with emphasis on Goal oriented requirement engineering framework”GORE” (**i\* framework**), business intelligence modelling(**BIM**) and porter’s five forces model of competition(**FFM**). GORE has been introduced as a means of modeling and understanding the motivations for system requirements. Using models to make goals explicit helps to avoid system failures due to implementing the wrong requirements or ignoring certain stakeholder needs. Therefore extending this GORE idea to strategic decision making, will provide a systematic decision making process, FFM model is a simple and generic decision making technique that can be applied almost to any industry therefore this would provide some interesting and useful results comparing and contrasting it with GORE as a decision making technique.

Hence in this work presents a logical approach that links and synchronizes these business tools to improve and facilitate strategic goal reasoning and decision making process.

### 3.1 Goal-Oriented Requirement Engineering GORE

Goal-Oriented requirement engineering (GORE) provides an incremental approach for elicitation, analysis, elaboration & refinement, specification and modelling of requirements. GORE frameworks allow for the representation of one or more goals, which may be derived from the system or system stakeholders, and which may have relationships to other goals, often describing how a goal can be achieved, or if a goal negatively impacts other goals. Such models allow an explicit consideration of system or stakeholder goals in the RE process. Various Goal Oriented Requirement Engineering (GORE) methods exist for these

---

\*Business modelling is a set of techniques used to represent and to structure the knowledge of business enterprise.

requirement engineering processes like KAOS, GBRAM ,Istar framework [41]. In this study we focus on the Istar framework.

### 3.1.1 Istar Framework

The i\* framework models intentional dependency relationships among strategic actors and their rationales. Actors depend on each other for goals to be achieved, tasks to be performed, and resources to be furnished. The concept of soft goal is used to model quality attributes for which there are no a priori, clear-cut criteria for satisfaction, but are judged by actors as being sufficiently met (“satisfied”) on a case-by-case basis. The framework was developed to support requirement analysis and high-level design in an agent-oriented system development paradigm. The framework includes a Strategic Dependency model for describing the network of relationships among actors, and a Strategic Rationale model for describing and supporting the reasoning that each actor has about its relationships with other actors.[32]

#### The Basic Strategic Dependency Model

A Strategic Dependency (SD) model consists of a set of nodes and links. Each node represents an actor, and each link between two actors indicates that one actor depends on the other for something in order that the former may attain some goal. We call the depending actor the “dependor”, and the actor who is depended upon the “dependee”. The object around which the dependency relationship centres is called the “dependum”. By depending on another actor for a dependum, an actor (the dependor) is able to achieve goals that it was not able to without the dependency, or not as easily or as well. At the same time, the dependor becomes vulnerable. If the dependee fails to deliver the dependum, the dependor would be adversely affected in its ability to achieve its goals.

The Strategic Dependency model distinguishes among several types of dependen-

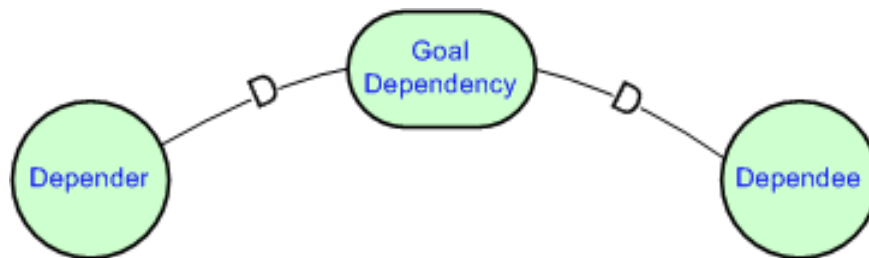

Figure 3.1: Illustration of Strategic Dependency model

cies, based on the ontological category of the dependum. In a goal dependency, an actor depends on another to make a condition in the world come true. In a task

dependency, an actor depends on another to perform an activity. The depender's goal for having the activity performed is not given. The activity description specifies a particular course of action. In a resource dependency, an actor depends on another for the availability of an entity. The depender takes the availability of the resource to be unproblematic. softgoal dependency, is a variant of the goal dependency. It is different from a (hard) goal dependency in that there is no a priori, cut-and-dry criterion for what constitutes meeting the goal. The meaning of a softgoal is specified in terms of the methods that are chosen in the course of pursuing the goal. The dependee contributes to the identification of alternatives, but the decision is taken by the depender.[32]

### Roles, Positions, and Agents

In  $i^*$ , the term actor is used to refer generically to any unit to which intentional dependencies can be ascribed. To model complex relationships among social actors, they further defined the concepts of agents, roles, and positions, each of which is an actor in a more specialized sense. A basic Strategic Dependency model can be extended by refining the notion of actor into notions of role, position, and agent. An agent is an actor with concrete, physical manifestations, such as a human individual. A role is an abstract characterization of the behavior of a social actor within some specialized context or domain of endeavour. A position is intermediate in abstraction between a role and an agent.[32]

### The Strategic Rationale Model

The Strategic Rationale (SR) model provides a more detailed level of modelling by looking "inside" actors to model internal intentional relationships. Intentional elements (goals, tasks, resources, and soft goals) appear in SR models not only as external dependencies, but also as internal elements arranged into a hierarchy of means-ends and task decomposition relationships. On addition to the decompositions, there are contribution relationships(hurt, help, break,some+, some-,unknown).Figure 3.2shows part of the RCCL goal model[16]. The model shows a dependency relationship between two actors namely; "RCCL IT dept" and "RCCL"for example, "RCCL" depends on the "RCCL IT dept" to satisfy the goal "To keep up to date with IT systems".The RCCL goal "To increase revenue" illustrates AND- refinements with the decomposition into sub goals of "To keep up to date with technology" and "To get more customers" while the "RCCL IT DEPT" goal "To integrate RCCL systems" illustrates the OR-refinement with a decomposition into three alternatives "To maintain current system", "To integrate web reservation system" and "To create flexible infrastructure to the dynamic user requirements".The goal "To maintain the current system" hurts the soft goal "Reduce costs",This means the satisfaction of the goal "To maintain current system" gives partial evidence that the soft goal can be denied,well as the goal "To

integrate web reservation system” gives partial evidence for the fulfillment of the soft goal ” Increase revenue” since it has ”help” contribution link. Some+ (some-) give unknown positive(negative) contribution to the destination goals(soft goals).

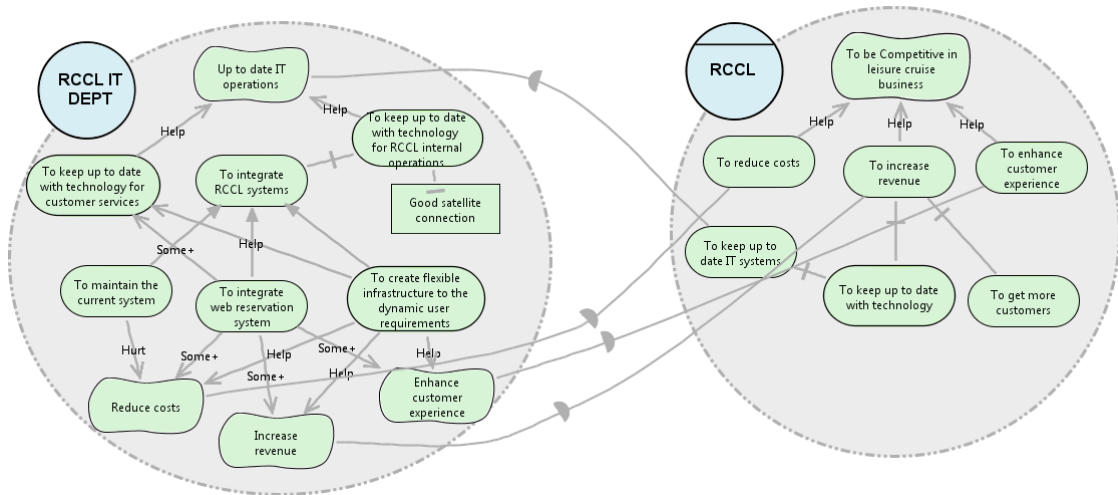

Figure 3.2: A diagram showing Istar Relationships.

These will be further explained in the next section since BIM extends the I\* framework and more goal models are illustrated in section 4

### 3.1.2 Business intelligence models (BIM)

As an extension on the i\* framework, BIM is a modelling language for representing strategic goals of the enterprise. It aims at bridging the gap between business level understanding of the enterprise with its representation in the databases or data warehouses i.e., the business-data gap in business intelligence [26]. BIM uses primitive concepts [26] and these include goals, indicators, situations, influences, task, and domain assumptions. This language facilitates the understanding of the enterprise at a strategic level and provides a business-user friendly way to use huge amounts of enterprise data. Figure 3.3 shows a running example of the RCCL business intelligence model.

#### BIM Primitive Concepts

This section describes the primitive BIM concepts i.e. Goals, tasks, links (influences), domain assumptions, situations and indicators. Although this is not the main emphasis of this study, it's worth mentioning and describing these concepts because they give the basis of the reasoning and analysis. The RCCL example in figure 3.3 is used to illustrate the BIM concepts and it will be developed in later



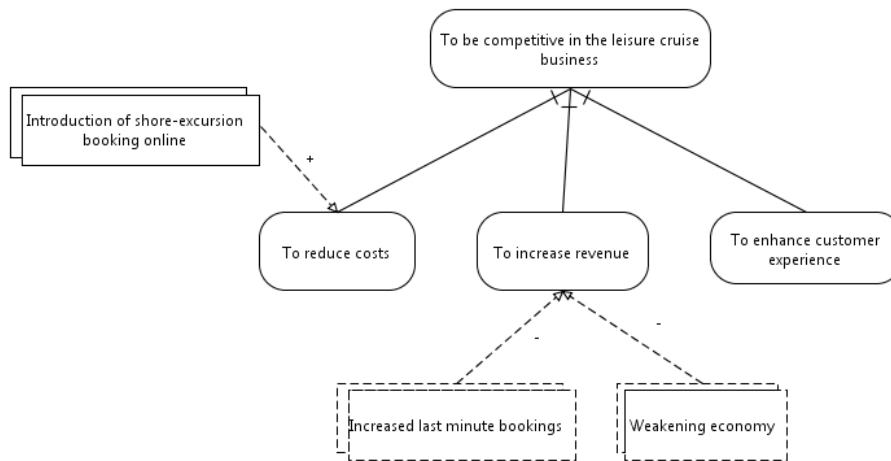

Figure 3.3: A diagram showing RCCL business intelligence model.

sections.

**Goal and Domain Assumption** This is a representation of the company’s objective. It can be OR/AND–refined into sub goals hence the root goal satisfaction will depend on the leaf goals. The satisfaction of a goal can also depend on satisfaction of other goals other than its sub goals. Therefore a goal model consists of AND/OR refinements with positive and negative influences. Considering the running example, the goal “To be competitive in the leisure cruise business” is AND refined into three other sub goals; “To increase revenue” and “To reduce costs” and “To enhance customer experience”. Domain assumption although not shown in the example, is a condition that must be true to achieve a root goal. Depending on the amount of available information, the goals can be refined down to the last leaf goals. In the analysis, the leaf goals will be given a truth assignment and this gives alternatives on how the root goal can be satisfied. The satisfaction of a goal can be derived from the satisfaction of other goals or sub goal using label propagation algorithms.[18]

**Situation** BIM support SWOT analysis and reasoning. SWOT standards for strength, weakness, Opportunities and threats. BIM captures these concepts using the notation of situations. Situations can be internal or external and favourable or unfavourable to some goals. If an internal situation is favourable (has a positive influence) to a goal then its converted into strength unlike when it’s unfavourable it’s converted to weakness. Same metrics is applied to the external situations which are converted to either opportunities or threats to the goal. A situation may be favourable to one goal and unfavourable to the other goal. This can be represented by influence links; positive and negative respectively. From the example the situation “Weakening economy” constitutes negatively to

the goal “To increase revenue” while “Introduction of shore excursion booking” influences positively the goal “To reduce costs.

**Influences** Influence is a concept used to relate situations and goals even when they are not from the same sub-tree. BIM supports two types of influences i.e. logical and probabilistic. Influences are also seen as contributions. Situations contribute to goals and goals also contribute to other goals. With logical influences, one goal/situation influences another if its satisfaction/denial implies (partial) satisfaction/denial of the other and modelled using qualitative values while probabilistic influence estimate the probability of a goal being satisfied (denied) given the satisfaction (denial) of another goal.[26]

**Indicators** An indicator is a metric that evaluates performance with respect to the business strategic objective. Therefore an indicator is a quantitative value that determines the level of satisfaction of the goal using the given metric as evaluation parameters. These values derived from data, or can use a formula to combine values. From the example the indicator “sales volume” evaluates the goal to “To increase sales volume”. The performance measures are normally applied in a hierarchical aggregation where the top level indicator is defined in terms of the lower level indicators. This approach enables reasoning with indicator technique which is described in the next section.

### **Reasoning with BIM**

Business intelligence modelling language in literature supports several reasoning. Some of the reasoning techniques are presented in this section and they include; Goal model reasoning and SWOT situational reasoning. Both are based on the BIM primitives.

**SWOT situational analysis.** Every company is confronted with a variety of internal and external forces which, on the one hand can comprise potential stimulants, or on the other hand can compromise potential limitations as regards the performances of the company or the objectives the company wishes to achieve. Internal forces or factor to the enterprise are classified as strength and weakness while external factors are classified as opportunities and threats. This kind of analysis and classification is referred to as SWOT analysis. BIM uses the situation and goal primitives to capture the enterprise internal and external forces. SWOT analysis can help to select among alternative strategies, and to determine their viability. Competitive advantage can be recognised by matching strengths to opportunities. A conversion strategy would convert weaknesses or threats into strengths or opportunities.[23]

### **Goal reasoning**

#### **Goal propagation and probabilistic decision analysis**

This kind of reasoning technique is supported by various tools other than BIM.

This analysis propagates the goal models with the AND/OR-refinements. For example If the root goal is refined with an AND then it will be satisfied if all the root goals are satisfied. Goal reasoning supports both forward and backward qualitative and quantitative reasoning.[18][21]

This will provide the administrators or managers with the possibility to choose among alternatives (Strategies).The forward/ backward algorithms starts with the assignment of a satisfaction values to some of the leaf goals in the goal model. Then it propagates the values forward/backward [21] to the root goal following some predefined rules. This represents a strategy that could fulfill the satisfaction of the root goal [26]. BIM supports both qualitative and quantitative reasoning but for this particular study, will focus on the qualitative reasoning. While performing qualitative analysis on the model, values are assigned to the goals. These values show the level of positive and/or negative evidence received via relationships with other goals [26].Here qualitative satisfaction is propagated by through the model using semantics of model links.ie decompositions(and/or) and influences(+,-,++,-) using the predefined labels(PS,PD,FS,FD) as described by Giorgini et al [18].

Additionally it might be possible to extract some probability about the likelihood of achieving a given goal given the satisfaction of the other goal but this would depend on the level of information available about the organisation. This provides an alternative on how to make strategies while making strategic decisions.

#### **Probabilistic decision analysis**

Depending on the amount of information about from the domain experts, decisions can be made at different decision points. A given goal can be satisfied following the satisfaction of other goal model elements. This is called a conditional probability.hence we are able to perform automated strategic reasoning using conditional probabilities and utility.

To carry out this decision analysis, a BIM model needs to be projected into an influence diagram. Such projections require a set of translation rules. [26] namely:

1. Goals, processes, domain assumptions and situations are translated to Chance Nodes, meaning that they are they represent uncertain quantities relevant to the decision problem; the uncertainties quantified by conditional probability distributions.
2. AND-Decomposition links<sup>†</sup>are translated into an influence links if the target nodes are Goals but removed if the target is a Domain Assumption <sup>‡</sup>.
3. OR-Decomposition link in BIM is translated into a Decision Node

---

<sup>†</sup>AND-Decomposition is not really a decision problem; however its translation is necessary in case it belongs to an OR-Decomposed sub-tree

<sup>‡</sup>since its truth value is not influenced by whether the parent goal is been pursued or not

4. Influence links among Domain Assumptions and Situations, as well as those having goals as the source or target node, are translated into Influence links<sup>§</sup>

### Indicator reasoning

This supports reasoning over indicators, using current values to calculate composite indicators. Composite indicators are those whose values are obtained from their components. In case the components are also composite this results into an aggregation hierarchy of indicators. Therefore indicator reasoning supports propagating of values from the lower level indicator to the top level indicator using either available unit conversion factors or unit normalization, allowing for optional indicator weights.[26]

### Hybrid Reasoning

Model construction typically consists of mixing of strategies planning and goal identification combined with the elicitation and understanding of existing business indicators. Therefore hybrid reasoning was proposed in the [26].Hybrid reasoning combines reasoning with indicators with the already mentioned reasoning techniques. This enables reasoning with incomplete indicators[26]

### 3.1.3 Strategic Goal Evaluation

Goal models are propagated by two common techniques; bottom-up and forward analysis. These kinds of analysis starts with an assignment of satisfaction values to some goals in the goal model and then propagate these values up to the root goal following the label propagation algorithm .The algorithm supports qualitative analysis but also allows two values over each goal (Satisfied, denied), qualitative satisfaction and denial is propagated through the model using the semantics of model links i.e. decomposition and contribution [18]. Contribution links between goals can be negative or positive, symmetric or asymmetric, and can have varying strengths [26]. The different assignment combinations correspond to the company strategies. Goal model propagation specifies what level of evidence propagated through what relationships produces what resulting level of evidence.[26] Section 5 describes the goal evaluation in details

## 3.2 FFM of competition

This model was developed by Michael porter in his book [35] in 1980. The model is based on the insight that the corporate strategy should meet the opportunities and threats in the organisation's external environments. The strategy should also be based on the understanding of the company structures and the way they change. Porter based his model on three assumptions;

---

<sup>§</sup>the strength of the original influence link will not be used in the Influence Diagram; instead the user needs to define the conditional probability table for the source and target nodes

1. That buyers, competitors, and suppliers are unrelated and do not interact and collude.
2. That the source of value is structural advantage (creating barriers to entry)
3. That uncertainty is low, allowing participants in a market to plan for and respond to competitive behavior.

Porter identified five competitive forces that shape the any industry or market and they determine the intensity of competition hence profitability and attractiveness of an industry. Therefore the objective of corporate strategy should be to modify these competitive forces in a way that improves the position of the organization. FFM include;

- Threat of new Entrants
- Power of suppliers
- Power of customers
- Availability of substitutes
- Competitive rivalry

The FFM can provide valuable information for three aspects of corporate planning, namely; statistical analysis, dynamic analysis and analysis of options. Focusing on the last aspect of analysis of options, with the knowledge about intensity and power of competitive forces, organizations can develop options to influence them in a way that improves their own competitive position. The result could be a new strategic direction, e.g. a new positioning, and differentiation for competitive products or services.

The Porter's FFM tool is a simple but powerful tool for understanding where power lies in a given business situation. This is important, as it helps to understand both the strength of the current competitive position, and the strength of a strategic position the company wishes to move into. With a clear understanding of where power lies, the organisation can take fair advantage of a situation of strength, improve a situation of weakness, and avoid taking wrong steps.

### 3.3 Uncertainty model

Uncertainty is lack of complete knowledge about a state or quantity. There is always more than one value and the "True" value is always unknown. Uncertainty can be measured as a set of possible values with a probability assigned to each. This model was first proposed for requirement engineering uncertainties. In RE, always something is known about the requirements of the system although uncertainty is always large. Therefore the model suggests six steps [12];

1. Model the design decision problem.
2. Define decision risks(model and parameter uncertainty)
3. Elicit what is already known (to decision makers)
4. Shortlist candidate architectures based on expected value, costs and risks.
5. capture the expected value of information
6. Seek additional information where valuable (create posterior distribution)

This step by step model (approach) is applied to the developed company and economic models to determine a favorable strategic goal. Therefore in this study we compare the five force model analysis with strategic goal analysis and draw the complementarity between the two techniques for decision making

## Chapter 4

---

# Case Study

---

### **Royal Caribbean Cruises Ltd**

The case study used in this chapter is based on RCCL and motivated by the situation Murphy faced, he had three alternatives to choose and implement only one. It also provides situations and scenarios that can be captured by goal models hence giving a favorable environment for comparisons with the FFM. This enabled showing how the goal modeling analysis can be used for systematic strategic decision making compared to the current exiting technique of five force model analysis.

### **4.1 Case Study Description**

RCCL was founded in 1969 by Edwin, W Stephen with an idea to create pleasure cruise ships in the Caribbean but later this expanded to other areas of the world. Since then RCCL expanded with two main brands and was ranked the second largest cruising company. The competition in this business was less with only three dominant players in the market. But in 2001 RCCL faced a challenge and decrements in revenue as a result of the September 11<sup>th</sup> tragedy and also later in 2003, the SARS out breaks also was a blow to the company. Hence RCCL lost the glory days but in quest to restore the glory days, RCCL through its CIO Murphy, decided to invest in Information technology(IT) as one of the strategies to restore the glory days. However the implementation of IT should align with the company's objective and goals. Therefore Murphy has to decide which strategy the IT department should implement without harming but rather boosting the company objectives. Murphy has to decide whether to recommend a modest budget increase, insignificant budget increase or return to the glory days before the 9/11 events.[16]

## 4.2 Methodology

The case study was done in two main parts i.e. modelling and analysis. Modelling was carried in an iteratively until when the entire team agreed upon one goal model that depicted the RCCL case study information [case study]. After deciding on the goal model, we translated it into BIM using **BIM tool** [26] by adding situations and domain assumptions. Likewise this was iterative since it needed us (the entire team) to agree upon the BIM representation. Next we iteratively modelled the five force model and with guidance from **Carson** business field expert. Now with both the FFM and RCCL Business intelligence models, we identified how RCCL goals (situations) would affect the FFM and vice versa. Having agreed upon the relationships (contribution links) between the two models, we carried out the analysis. The analysis was carried out in three segments; “plain” goal model analysis, detailed goal analysis and probabilistic situational analysis(Risk analysis). Plain goal model analysis was performed using **open OME tool** using the forward and backward evaluation while detailed goal analysis and probabilistic situational analysis on both the goal model and BIM where done manually (using hand). All the analysis was carried iteratively and completed upon agreement of all the members. After which all the results and models were documented in this thesis.

## 4.3 Modelling Decisions

Modelling the case study involved making a number of decisions on how to represent the different attributes (concepts).The modelling consists of mainly two types of models, i. e. Business intelligence model (BIM) and strategic goal model. The business intelligence model is comprised of two sub models (RCCL model and FFM). This is modelled in this way because there was need to investigating how the strategy implemented by the organization to satisfy its main objectives performs according to the FFM. The strategic goal model as described in chapter 3, they involve decomposition of goals using AND/OR refinements. This section describes how the models where designed and why they were modelled that way.

### 4.3.1 RCCL Strategic Goal Model

The case study was mainly focusing on the use of information technology to improve the performance of the company(RCCL). Therefore it highlighted a number of objectives that could be achieved by the information technology department to enhance other departments’ performance and the company as a whole. Using the i\* framework [32], the scenario is represented by four main actors and linked with dependency links to show how they depend, contribute or influence each other.



The  $i^*$  concepts used in the model include;

#### **Actors**

Actors include RCCL, IT department, Human resource department and procurement department. These are detailed below.

#### **RCCL**

This represents the company as a whole. Here we illustrate the company overall objectives and all other actors will have contribution links to and this actor (RCCL).

#### **Information Technology Department**

The case study is focusing on how **IT** can be used to achieve the company's three legged strategy. Therefore the IT actors has goals that should influence the RCCL actor as well as other actors in order to satisfy the company overall objective.

#### **Procurement department**

This actor was selected and modelled because it's the procurement department that deals with the buying of raw materials needed by the company. But one of the main objectives was to reduce costs on the supply chain therefore we needed to show how this can be achieved basing on the procurement activities.

#### **Human Resource department**

In order to manage the employees it required us to know the goals of the HR department and how they influence the company goal of managing employees and their information.

RCCL's main objective is to stay competitive in the leisure cruise business. But in order to achieve this, they set a three legged strategy. This strategy involves

1. Enhancing customers' experience
2. Reducing costs
3. Increase revenue.

According to RCCL, they had to satisfy all the three objectives in order to be competitive in the leisure cruise industry. Therefore in the goal model this was illustrated as in figure 4.1. The root goal "To be competitive in the leisure cruise industry" is a soft goal because its' not measurable (If it is satisfied or not) and the sub goals "To reduce costs", "To increase revenue", "To enhance customer experience" contribute to the soft goal with "Help"\* influence link.

#### **1. Enhancing customers' experience**

RCCL to enhance the customer experience it had to enhance both customers' travel and trade experience. In the model this is represented as

---

\*Help was used instead of the AND refinement because OpenOME tool couldn't support the reasoning having the hard goal as the main goal with AND refinements.

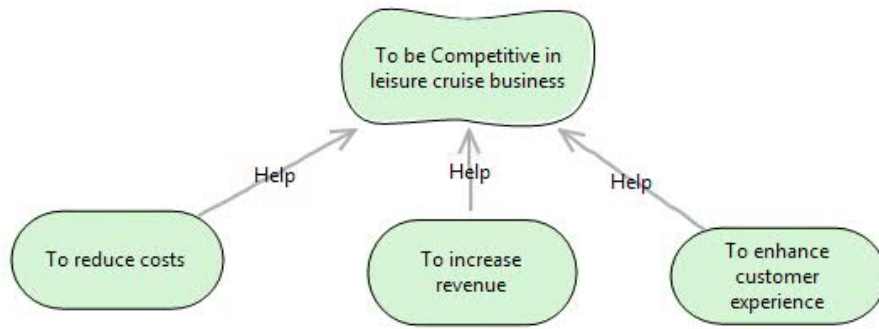

Figure 4.1: Figure shows the RCCL strategy (Goal model)

”AND” -refinement as in figure 4.2. But to enhance customer travel experience RCCL had to provide support call centers and an integrated web reservation system [16]. The goal ”to provide an integrated web reservation system” depends on the IT department therefore it will only be satisfied if the IT department goal “To develop an integrated web reservation system” is satisfied. The IT department goals are shown in Figure 4.4 on page 45 To enhance customer trade experience, RCCL had to provide better vacation experience and to keep track of the customer preferences. In order to keep track of the customer preferences the company had to carry out an analysis “Customer consumption analysis” which would help to determine what things are consumed more by the customers so that they are made available to the customers. To provide a better vacation experience, RCCL had to provide embarkation and disembarkation cards to the customers. There are other factors that influence this goal as shown in the model, Figure 4.4.

## 2. Reducing costs

Reducing costs involved reducing costs on the supply chain and also on the IT infrastructure. For RCCL to reduce costs it had to achieve both therefore represented as ”AND” decomposition as in Figure 4.3. The goal “To reduce cost on supply chain” is further AND decomposed into “To reduce costs on technical supply chain” and “To reduce costs on hotel supply chain”. Reduction of costs on supply chain is also positively influenced by the IT goal to integrate the supply chain as in the Figure 4.4.

## 3. Increase revenue

A number of factors had to be considered by RCCL in order to increase its revenue, among them we identified the main four that should be satisfied namely;

*To redesign the ship*

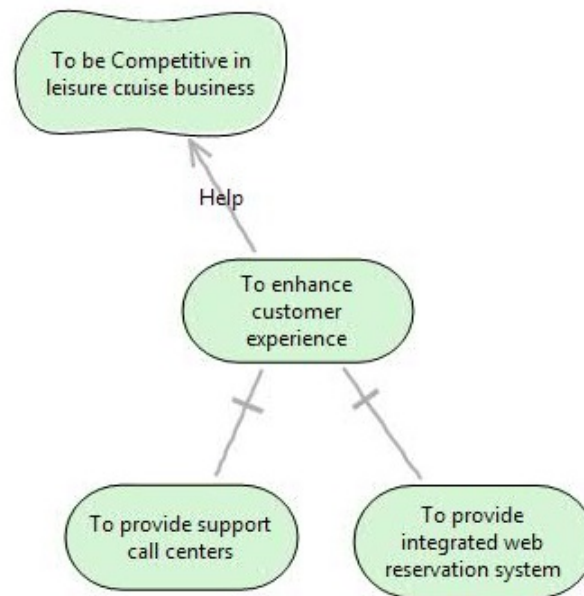

Figure 4.2: shows "To enhance customer experience" decomposition.

*To offer new improved services*

*To get more customers*

*To keep up to date with technology.*

Redesigning the ship meant to replace the diesel engines with gas engines. This would free up space for fifty five cabins. This means the ship would accommodate more customers and hence increase in revenue. In addition to increase in revenue, this would also reduce noise which would help to enhance the customer experience as shown in Figure 4.4.

*To offer new improved service* could be achieved by offering new pleasure service which included providing high speed Internet cafes, buying new ship, providing shore excursion and the silverware program. These were all modelled as "AND" -refinement since all had to be satisfied in order to offer new improved services.

*To get more customers* involved to offer more sales channels, increasing ship capacity and improving customer services thus modelling all the three alternatives with AND refinement. RCCL only had two possible sales channels i.e. through agents and web reservation system, therefore the goal "To offer more sales channels" is "AND" -refined into two sub goals "To get customers via agents" and "To get customers via web". Through agents, customers could make bookings online or through call centers. These are represented as sub goals with "AND" -refinement of the goal "To get customers via agents"

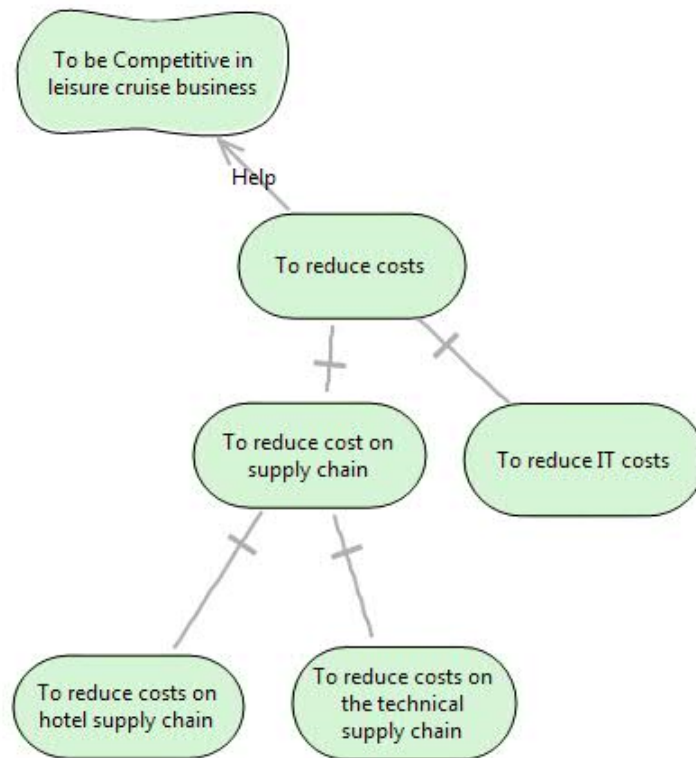

Figure 4.3: Figure shows "To reduce cost" decomposition.

*Information technology department* aims at keeping the company up to date with technology. In order to achieve this goal, according to Murphy the department had to support the business and hence setting up the leapfrog project. This was to handle the employee system (employees), supply chain and web reservation system (customers). Therefore while modelling, these were divided into two goals, "to keep up to date with technology for customers" and "to keep up to date with technology for RCCL internal operations" where internal operations covers both supply chain and employee systems but also includes the web reservation system because according to the case study, the web reservation is also used by the RCCL to keep track of its customers.

As mentioned earlier the main goal of the IT department is to keep up date with technology. To achieve this, the IT department had to keep up date with technology for both customers and internal operations. To keep up date with technology for internal operations, IT had to integrate the RCCL systems assuming that there was a good satellite connection because it was needed for communication between the ship and the shore (land) offices. Therefore to integrate the RCCL system, the department had to decide on which alternative would facilitate the

achievement of the main department goal as well as fulfillment of the RCCL main goal. The alternatives included;

- To create flexible infrastructure to the dynamic user requirements<sup>†</sup>
- To maintain the current system<sup>‡</sup>
- To integrate web reservation system<sup>§</sup>

Since this was a decision point, it was modelled as a mean-ends (“OR “refinement) more specifically as exclusive OR (XOR) and each was further decomposed into other sub goals. It’s at this point where the main three alternatives as described in the case study description and in citefourteen, are captured in the model and shown how each alternative influences the satisfaction of RCCL’s main objective(goal).

*To maintain the current system*

To maintain the current system would require maintaining the same budget on condition that the system is integrated. This is modelled as 2AND” -refinement passing the condition as a resource. But since it’s ”AND” according to the i\* framework this would mean the resource has to be available for the satisfaction of the root goal. The goal “to maintain the same budget” will break any alternative that involves changing the budget as well influencing all the other goals that are related to the RCCL systems as shown in Figure 4.4.

*To integrate web reservation system*

To integrate the web reservation system required investment of eight million dollars on infrastructure, untangling the seven reservation system and also developing an integrated web reservation system. Investing the eight million will lead to denial of both the ”to maintain the same budget” and ”to invest a much sharper budget”. But it will help or positively influence the goal ”to have a single view of customer history” and the goal ”to keep up to date with technology for customers”.

*To create flexible infrastructure to the dynamic user requirements*

To achieve this goal the IT department had to invest a sharper budget that would bring quicker changes compared to the 8 million in alternative 2. In addition to the investment of sharper budget, the department also had to automate the supply chain and human resource system (Peoplesoft). The IT department also had to consolidate servers and in the process this helped RCCL to reduce IT costs. All these sub goals had to be done in parallel to achieve the root goal hence ”AND”-refinement. Since the alternatives are in exclusively ”OR” relationship, the investment of a sharper budget will deny the other two alternatives mentioned

---

<sup>†</sup>RCCL would invest much more money to develop all it’s IT systems impacting other sectors of the company

<sup>‡</sup>RCCL would leave its current infrastructure untouched hence nothing changes

<sup>§</sup>This only considers development of a single reservation system ignoring all other systems

earlier. To have an automated and efficient HR system required to automate the HR system and this involved upgrading PeopleSoft system and providing real time access to employee information. This would positively influence the goal soft goal “To have efficient HR system”.

To automate the supply chain the department had to integrate the supply chain and to upgrade the ERP system. This would improve the inventory management and create error free logistics. The model shows all the possible relationships between the actors and the goals. According the i\* framework, actors can depend on other actors’ goals or resources. Showing all the alternatives and RCCL goals linked by the influences and decompositions, now we are able to reason using the label propagation algorithm about the goal model and decide the best alternative is for RCCL.

### **RCCL Strategic Goal Model**



Figure 4.4: Figure shows "RCCL Goal Model.

### 4.3.2 Business Intelligence Models (BIM)

BIM represent the strategic goals of RCCL. BIM implements the istar framework in that it implements most of the Istar concepts on additional to its own other concepts like situations, domain assumptions and indicators as described in section 3. The BIM comprises of two sub models i.e., RCCL and Porter’s five forces model. This is because we needed to capture the different results on how the company performs with respect to the five forces given particular strategy. Unlike the strategic goal models in 4.3.1 BIM represents only the company’s strategic goals and how they can be achieved under the influence of given situations. Thus here we would expect more concrete results since it takes in account more other concepts that might influence the business as compare to the strategic goal model.

#### RCCL BIM

The case study shows that the main objective of RCCL is to remain competitive in the leisure cruise industry. Therefore in the model, this is represented as the root goal of the RCCL model. RCCL uses a three legged strategy in order to fulfill its main goal. All these three branches have to be full satisfied in order to fully satisfy the main company objective. This is represented as AND decomposition of the root goal .Figure 4.5 shows the goal “To be competitive in the leisure cruise business” as the root goal and it’s AND decomposed into three sub goals namely; “To increase revenue”, “To reduce costs” and “To enhance customer experience”. BIM implements situations which are used to capture both external and internal factors that may influence the business goals.

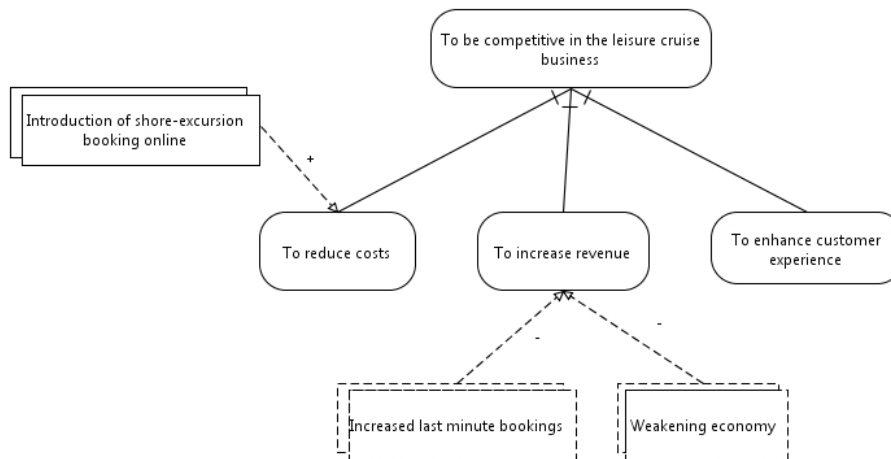

Figure 4.5: Figure shows Level 1 Goal decomposition.

In Figure 4.5 the goal “To increase revenue” is negatively influenced by the external situations weakening economy and “Increased last minute bookings”



while the goal “To reduce costs” is positively influenced by an internal situation “Introduction of shore-excursion program”. Three sub goals, each is further decomposed in to other sub goals and domain assumptions. Satisfaction of these sub refinements (sub goals) will contribute to RCCL strategies and they are described below.

1. To reduce costs In order for RCCL to reduce costs, it had to reduce costs on supply chain and Information technology. But the case study showed that the supply chain was divided into two sections; hotel supply chain and technical supply chain. Therefore costs had to be reduced on both hotel and technical supply chain. This was modelled as ”AND” decomposition of the goal “To reduce costs” and decomposed into two sub goals; “To reduce costs on supply chain” and “To reduce costs on IT” as shown in figure 4.6. The goal “To reduce costs on supply chain” is also further ”AND” -refined into “To reduce costs on hotel supply chain” and “To reduce costs on technical supply chain”. But since IT is part of the technical supply chain, the reduction in the costs of technical supply chain will lead to some reduction in the IT costs. Hence this is captured as a positive influence from the goal “To reduce costs on technical supply chain” to the goal “To reduce costs on IT”. It should be noted that goals are influenced not only by situations but also other goals and domain assumptions. Therefore the goal “To reduce costs” and its sub goals are influenced by other goals and domain assumptions as shown in Figure 4.11.

2. To increase revenue

The second leg of the strategy is to increase revenue. RCCL had implemented some new services in order to increase revenue as well as proposing more other implementations by the executive members like murphy. In order to increase revenue RCCL had to get more customers so as to increase the income, to offer new improved services and to keep up to date with technology. This is represented as AND refinement of the goal “to increase revenue” into three branches which should all be satisfied in order to increase revenue i.e. “To offer new improved services”, “To get more customers ” and “To keep up to date with technology”. These sub goals are further decomposed in to other sub goals as shown in Figure 4.11 but for this section we shall focus on the decomposition of all the sub goals.

#### **To keep up to date with technology**

According to Murphy, RCCL needed to keep on top with regards to technology because this was one way they would beat their competitors and attract more revenues. In order to achieve this, RCCL had to update the technologies related to both customers and the company’s internal operations. In the model this is reflected as AND refinement of the goal “To keep up to date with technology”.

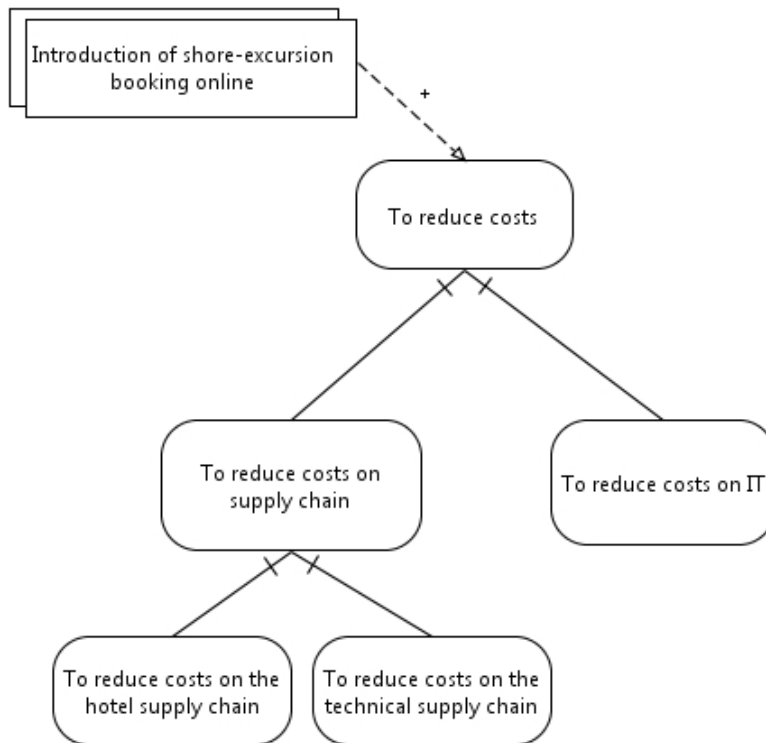

Figure 4.6: Figure shows Reduce costs decomposition.

According to the case study, it's not described how RCCL would keep up to date with technologies related to customer services but it's described how to keep up to date with technology related to internal operations will be satisfied. Therefore as a modelling decision, some activities or goals implemented under internal operation have an influence on the technologies related to customer services. The goal "To keep up to date with technologies related to internal operations" is AND decomposed into the goal "To integrate RCCL systems" and Domain assumption "Good satellite connection". Domain assumption is used to represent a condition that should always be satisfied for a root goal to be satisfied. Here since most of RCCL systems run on a network (Local and wide area networks), it needs a good connection to communicate between systems on sailing ship and in land servers. But this resource is not provided by RCCL thus represented as a domain assumption that should be presented. The goal "To integrate RCCL system" is decomposed into three other sub goals using OR refinement. The OR refinement represents an exclusively OR (XOR) and a decision point. XOR means the satisfaction of one alternative will deny all the other alternatives, therefore only one alternative can be implemented. At this point RCCL (Murphy) have to choice among the three the best alternative for

the company to fulfill its main objective. The alternatives include;

- A. To maintain the current system
- B. To integrate web reservation system.
- C. To create infrastructure flexible to dynamic user requirements

Each alternative represents a strategy that RCCL may implement and achieve the main goal “To be competitive in the leisure cruise business”. At this point the question is which is the best alternative and how do you identify it. This answer will be answered in the reasoning and strategy evolution section.

**Strategy A:** To maintain the current system

In order to maintain the current system, this would mean the current system is integrated and doesn't require any updates or integration hence RCCL won't need to invest on the integration of RCCL systems. The model captures this information with two domain assumptions under AND refinement as shown in Figure 4.7. Therefore in order to satisfy the parent goal both domain assumptions should be true.

**Strategy B:** To integrate web reservation system

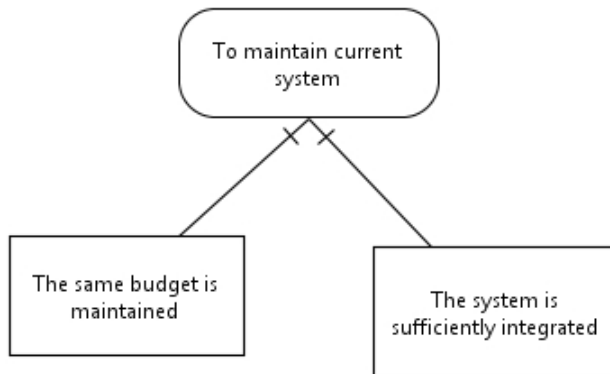

Figure 4.7: Figure shows Reduce costs decomposition.

The second alternative mainly focused on integrating the web reservation system. RCCL had up to seven untangled reservation system. So with this alternative, all the reservation systems will be integrated into one system but this would require an investment of eight million dollars. Therefore the investment of 8 million dollars will deny both the goal to “To maintain the current system” and “To create infrastructure flexible to dynamic user requirements”. But satisfaction of this parent goal will help RCCL to have a single view of the client history thus keeping up to date with the technologies related to customer services as shown in 4.11

**Strategy C:** To create infrastructure flexible to dynamic user requirements

The last strategy states that RCCL should invest even a much sharper budget than the eight million dollars to bring up quicker changes hence creating an infrastructure flexible to the dynamic user requirements. This would mean that RCCL will be able to implement most of its projects as described in the case study description [16]. Since all the alternatives are under an XOR relationship, implementing this strategy will mean denial of the other two strategies mentioned earlier.

This alternative is represented in the model as AND refinement of five sub goals; “To make a sharp increase in budget”, “To have an automated and efficient HR system”, “To improve security of online systems”, “To automate and simplify supply chain” and “To consolidate servers”. Each of the sub goals is further decomposed into other sub goals in order to show how they can be satisfied and how they can have an impact on other goals (Influences).

#### **To offer new improved services**

On addition to keeping up to date with technology RCCL had also to offer new improved services so as to increase the income. Therefore the company needed to increase on the process efficiency and also offer new pleasure cruising services because the main service provided by RCCL was pleasure cruises. Some of these services listed in the case study description include; on board internet cafes, buying new ship, shore-excursion and silverware program. These are all represented with AND refinement as shown in figure 4.8.

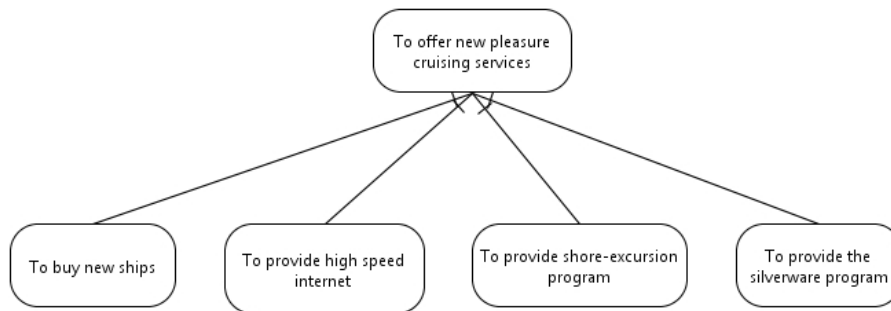

Figure 4.8: Figure shows To offer new cruising services.

#### **To get more customers**

Another way RCCL could increase its revenue was by increasing the number of customers. RCCL mainly focused on agents to sell its services to the customers therefore there was need to get more sales channels on addition to the agents hence getting customers via the web. Other than the sales channels, RCCL had to improve the customer services and also increase the ship capacities. The model represents this information as a decom-

position of the goal “To get more customers” using AND-refinement into sub goals “To offer more sales channels”, “To increase capacity” and “To improve customer services”. The external situation “Competition and new entrants” negatively influences the goal “to get more customers”. As previously statement to offer more sales channels RCCL had to introduce web reservation system on addition to agents. Therefore the goal “To offer more sales channels” is AND refined into “To get customers via web” and “To get customers via agents”. But it’s also noted that agents make customer bookings either using the web or through the call centers. Thereby refining the goal “to get customers via agents” into the goal “To get customers’ bookings via agents on line” and “To get customers’ bookings via RCCL’s call center” using mean-ends (OR) refinement.

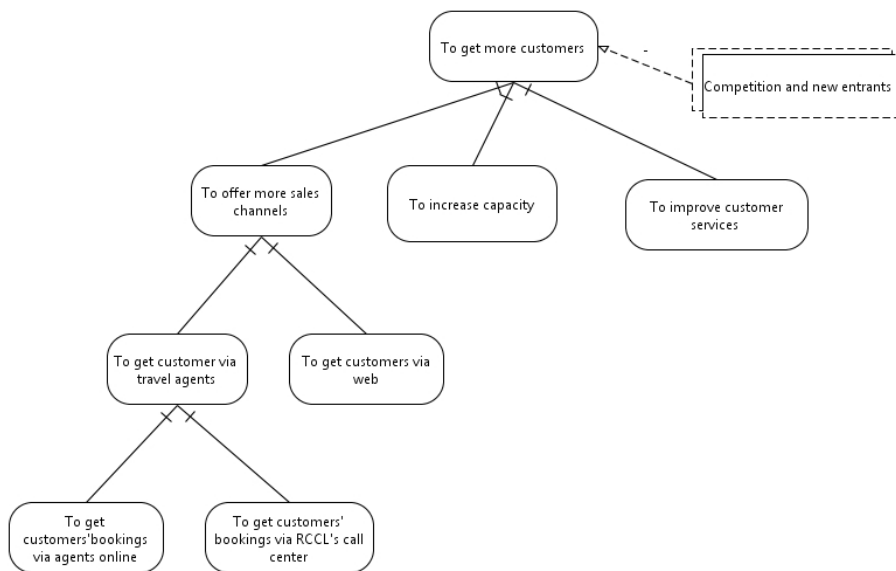

Figure 4.9: Figure shows get more customers.

### 3. To enhance customer experience

The third leg on the three legged RCCL strategy is to enhance customer experience [16]. According to RCCL, user experience is divided into two namely; travel and trade experience. Therefore the model represents this as AND-refinement of the main goal “to enhance customer experience” into “To enhance customer travel experience” and “To enhance customer trade experience”.

The goal “To enhance customer travel experience” is further AND-refined into “To know customers’ preferences” and “To provide a better cruising and vacation experience” because for RCCL to improve the travel experience it has to provide services exactly needed by customers hence the

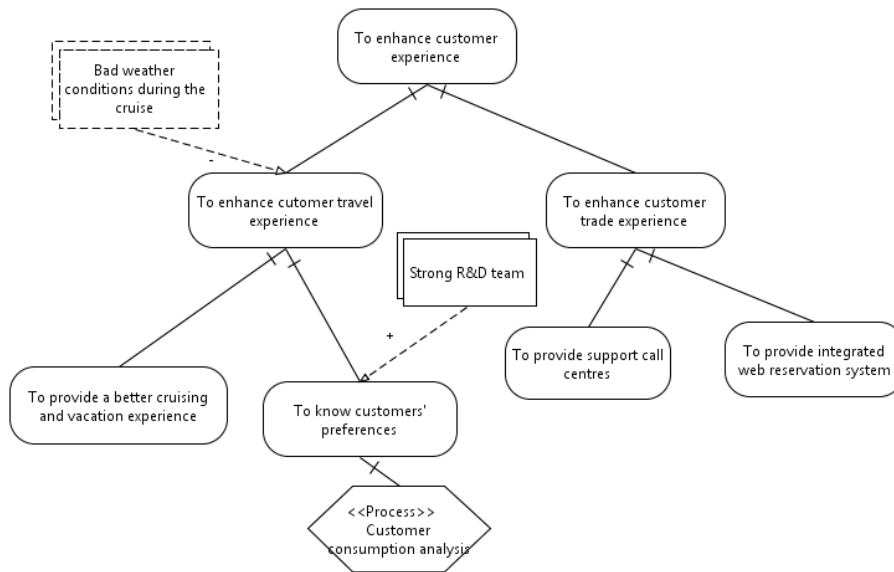

Figure 4.10: Figure shows To enhance customer experience Refinement

company has to know the customer’s preferences. This goal is also negatively influenced by an external situation “Bad weather conditions during the cruise” but also this will help the cruise company to provide better cruising and vacation experience to the customers. The task “Customer consumption analysis” represents a process that is performed to satisfy the goal “To know customers’ preferences”. This goal is also influenced by an internal situation “Strong R& D team”. This is because with presence of good R& D team will enable the company to do the customer preference analysis.

The goal “To enhance customer trade experience” can be achieved by providing support call centers where clients and agents can call to make bookings plus any inquiries and by providing an integrated web reservation system that would still help customers and agents to make bookings. Satisfaction of these sub goals will yield to enhancing of customer trade experience. Figure 4.10 shows the decomposition the goal “To enhance customer experience

### Influence Links

Influence links between the different BIM concepts depict how one concept affects the other, for example one goal may hurt(help) the other goal or one situation may hurt(help) a goal. RCCL model has a network of influence links but they are illustrated by the model in figure 4.11. The model also illustrates the entire RCCL strategic goal model, detailing all the goals ,situations, task , domain assumptions and tasks.

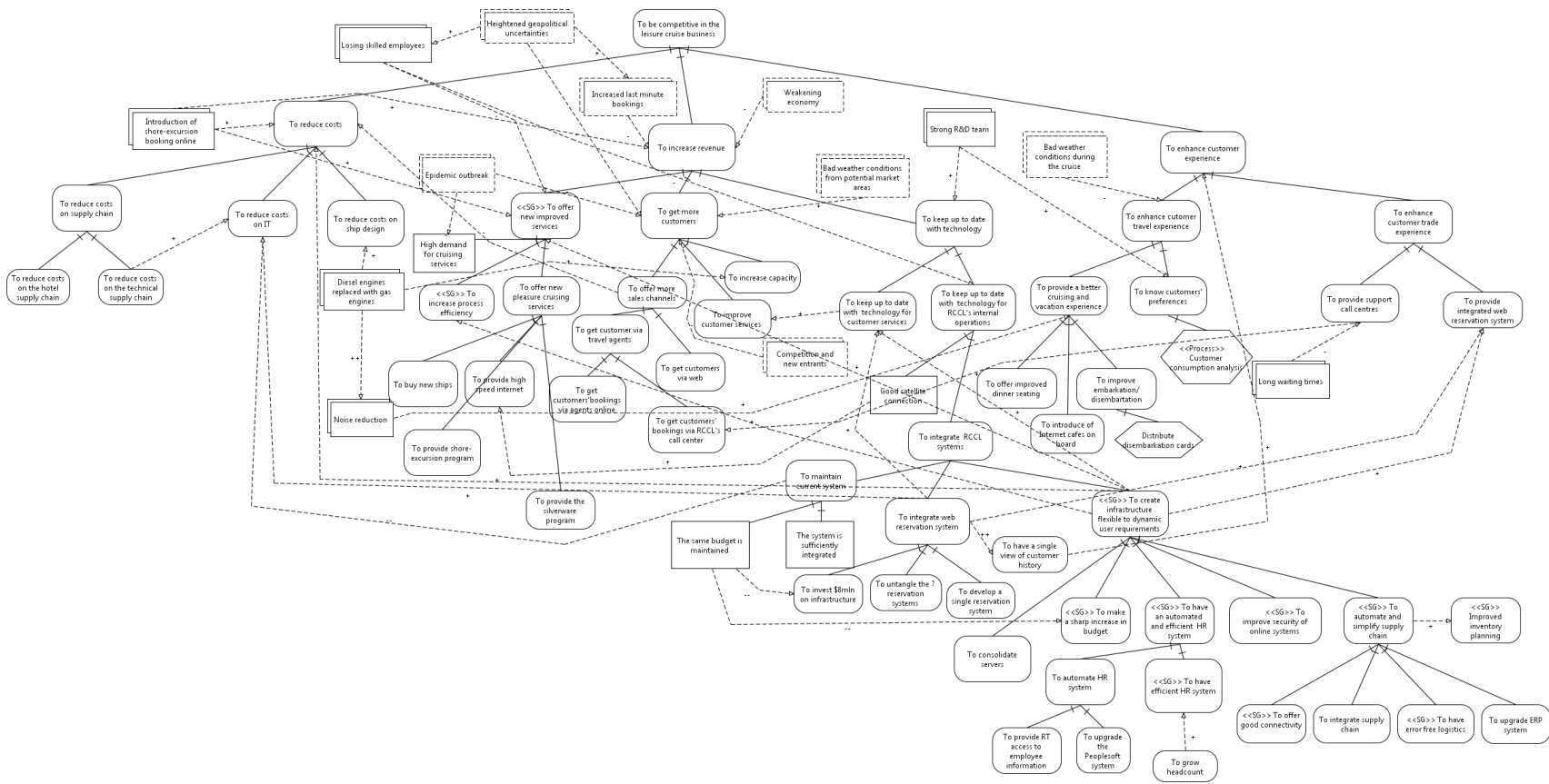

Figure 4.11: Figure shows RCCL Business Intelligence model.

### 4.3.3 Porter's Five Force model

FFM captures the concepts of five forces that determine the competitive advantage of an enterprise. This model gives a skeleton that other company models can be compared to in order to determine how the company is performing with respect to the five forces.

FFM is a framework for analyzing the nature of competition within an industry [37]. Therefore setting the main objective of all companies in the industry as "To be Strategically Strong". Following Porter's suggestion, there five forces that should be considered to satisfy the main objective. We used a goal model to illustrate FFM showing how each force(goal) can be satisfied and how they influence each other. Later in the model we included situations that might affect the five forces<sup>¶</sup> hence affecting the main objective(main goal). Figure 4.12 shows

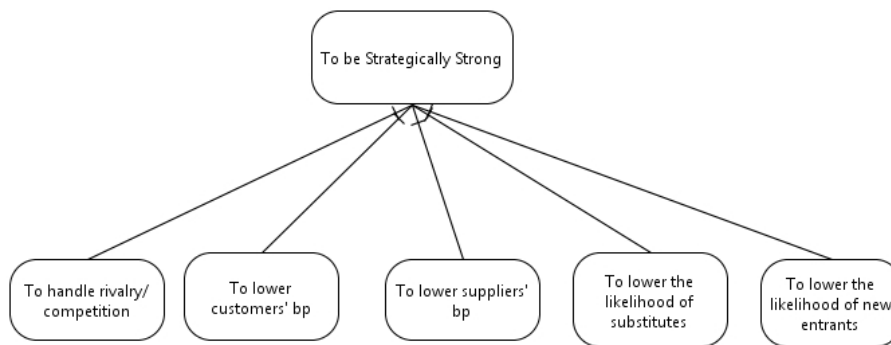

Figure 4.12: Illustration of Five forces model

the FFM with the root goal "To be strategically strong" which is "AND"-refined into five other sub goals. Each sub goal represent one of the five forces. Each of the goals is further decomposed into other sub goals or influenced by some external situations.

**To handle rivalry/competition:** This goal can be satisfied by increasing customer search/switching costs and hence obtaining differentiation in the industry. Hence in the model in figure 4.13 illustrates the "AND" decomposition of the goal "To handle rivalry/competition". But it also captures the external situation "Less competitors" that might help in the satisfaction of this goal.

**To lower customers' bp:** Companies can satisfy this goal by increasing the number of customers and lowering the economic importance of the customers but this can be negatively affected by availability of substitutes hence figure 4.14 shows the refinement of the goal "To lower customers' bargaining power" as a AND-refinement of the two sub goal and one external situation "Less competi-

<sup>¶</sup>For this study we shall focus on the main first three forces because of the information provided in the case study[16]



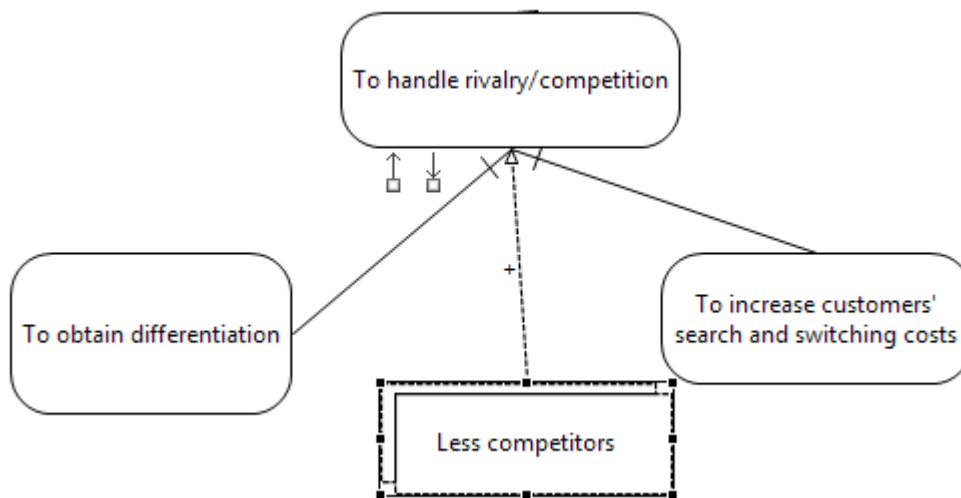

Figure 4.13: FFM; handle Rivalry/competition

tors” that helps the satisfaction of the goal.

**To lower suppliers’ bp:** Supply bargaining power can be reduced by lower-

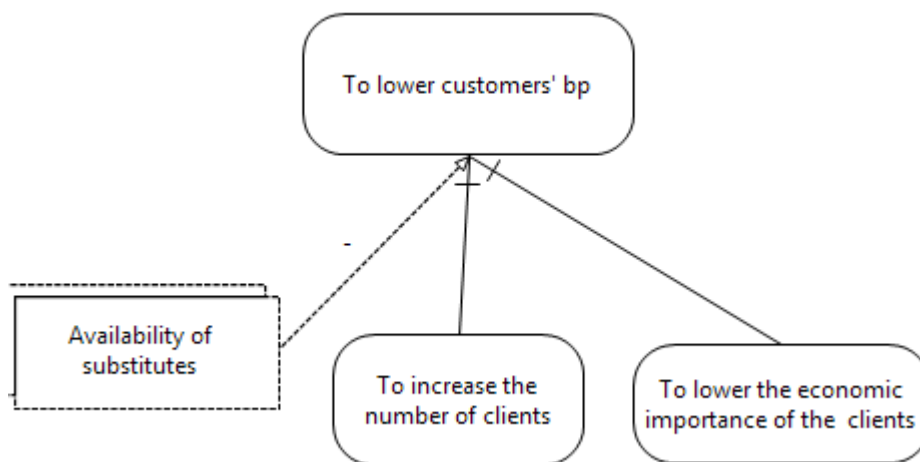

Figure 4.14: FFM: To lower customers' Bargaining power

ing the searching and switching costs of raw materials, in addition to lowering the importance of raw materials (from certain suppliers) to the organization or company. Figure 4.15 shows the decomposition of the goal “To lower suppliers’ bp”. It is “AND”-refined into “To lower search and switching costs” and “To lower the importance of the product to the firm”. The situation “Availability of alternative suppliers” can help with the satisfaction of the root goal<sup>||</sup>.

<sup>||</sup>Parent Goal

Figure 4.16 shows a detailed decomposition of FFM with all the forces included

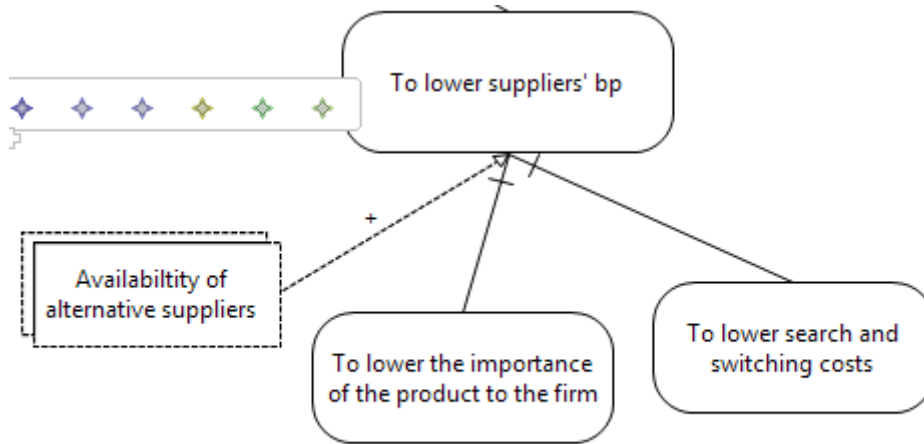

Figure 4.15: FFM:To lower suppliers' Bargaining power

and situation that might affect them.

We have represented FFM using BIM and shown how the different forces can be overcome. Therefore in the next section we describe how the RCCL model influences the FFM and vice versa via contribution links.

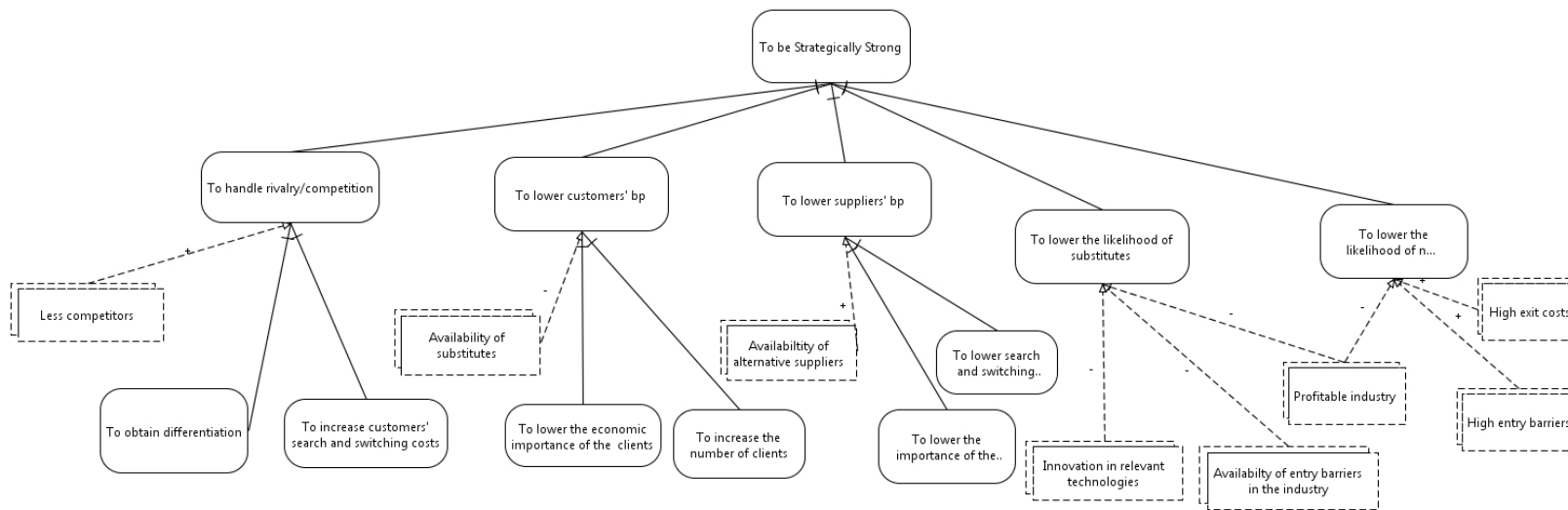

Figure 4.16: Illustration of Five forces refinements and External situations

#### 4.3.4 Relationship Between FFM and RCCL goal models

The previous sections we developed the RCCL and FFM models. In this section we shall investigate the relationship between the two models i.e, if RCCL implements a goal, how does it influence the FFM. Practically, this can be considered as a measure of the RCCL goals with respect to FFM. This relationship was captured using BIM contribution links(-, +, ++, --).

##### Relationships (Contributions links)

In table 4.1 we show some influences between the two models. The table re-

RCCL MODEL	INFLUENCE/CONTRIBUTION	FFM
To offer new improved services	+	To obtain differentiation
To enhance customer experience	+	
To get more customers	+	To increase the number of clients
To get customers via web	+	To lower suppliers' bp
To get customer via travel agents	-	

Table 4.1: Contributions between RCCL and FFM goals

flects  $RCCL \Rightarrow FFM$  relationship. For instance the RCCL goals "To offer new improved services" and "To enhance customer experience" illustrates a partial positive contribution to the FFM goal "To obtain differentiation" while the RCCL goal "To get customer via travel agents" contributes negatively to the FFM goal "To lower suppliers' bp".

The appendix shows Figure A.1, that illustrates all the relationships between the two models in both directions  $RCCL \Rightarrow FFM$  and  $RCCL \Leftarrow FFM$

Strategic Goal modeling is very important step in decision making but since it clarifies and communicates the business objectives and situations but much of BIM models (Goal models) come from the capability to support reasoning. Therefore the next chapter show Goal and FFM analysis in practise and how they support decision making.

## Chapter 5

---

# Evaluation and Results

---

This chapter shows the use of two strategic analysis techniques in practice, namely strategic goal and FFM analysis, comparing the two in terms of the support they provide in decision-making. The chapter first presents strategic goal modeling and analysis in section 5.1, then introduce FFM in Section 5.2 and finally compare the two techniques in Section 5.3.

### 5.1 Goal modelling and analysis

Goal models are diagrammatical depictions of user, system, or stakeholder goals and interrelationships.[27] GORE has been advocated to capture and link technical requirements to social needs to derive high-level or detailed system requirements using elicited goals. This helps to capture and compare alternative potential implementations while focusing on clear motivations for system requirements [27, 21]. In this study we use the goal models not to define system requirements but rather we consider it as an approach that focuses on the organization's ability to achieve its goals as illustrated in chapter 4. An organization's goals are identified by establishing the general company objective then discovering means or sub goals for its accomplishment and defining a set of activities for each objective. Following the istar framework described in chapter 3, we identified actors who represent stakeholders (Decision makers).Each stakeholder has objectives that need to be fulfilled, they are represented as goals and tasks.

Goal models contain links describing the contribution relationships between goals, tasks and Actors (e.g., help AND, OR, Dependency). They also support a systematic propagation of goal satisfaction hence answering some questions like "Will a particular design alternative work in the domain?" and "what are the consequences of its implementation?"

Figure 5.2 is extracted from section 4 to illustrate the Istar goal model and con-

cepts. We used Istar framework in this study because it supports some human judgement therefore the decision maker is able to explore all the possible alternatives. Goal satisfaction procedures start with initial values assigned to the model, reflecting an alternative or question, and then use model links to propagate values either forward (in the direction of the link) [9, 22] or backward [2, 21].

Istar analysis supports an interactive, qualitative reasoning in terms of qualitative labels representing satisfaction or denial, typically using: satisfied (to represent a sufficient level of goal satisfaction), partially satisfied, conflict, none/unknown, partially denied, and denied (to represent negative achievement), [9, 2]. In this type of analysis, labels are placed on the graph to indicate the selection of an alternative and are propagated throughout the graph taking into consideration dependency and contribution links, the final results shows if the main objective is satisfied or denied.

### 5.1.1 Dependency model



Figure 5.1: Illustration of dependency model

In a goal dependency, the depender depends on the dependee to bring about a certain state of affairs in the world. The figure 5.1 shows that RCCL depends on the goal “To invest 8 million” by the IT department. Therefore RCCL is the depender, the IT department is the dependee and the goal is the dependum. Formally the dependum is expressed as an assertion statement. The dependee is free and expected to, make whatever decisions are necessary to achieve the goal. The depender does not care how the dependee (IT) goes about achieving the goal [32]. This can be seen as a logical implication

Continuing with the case study of RCCL, suppose we are modelling the three alternatives of the IT department. These can be represented as goals but decomposed with OR refinement to represent a decision point. In this case the “OR” represents an **exclusively or (XOR)** since the department has to implement not more than one alternative at the same time. The main IT goal is represented as soft goal and can be satisfied if the IT department implements the two other sub goals of “to keep up to date with technology of RCCL internal operations”

and “To keep up to date with technology for customer services” as illustrated in figure 5.2 Focusing on the goal “to keep up to date with technology for RCCL

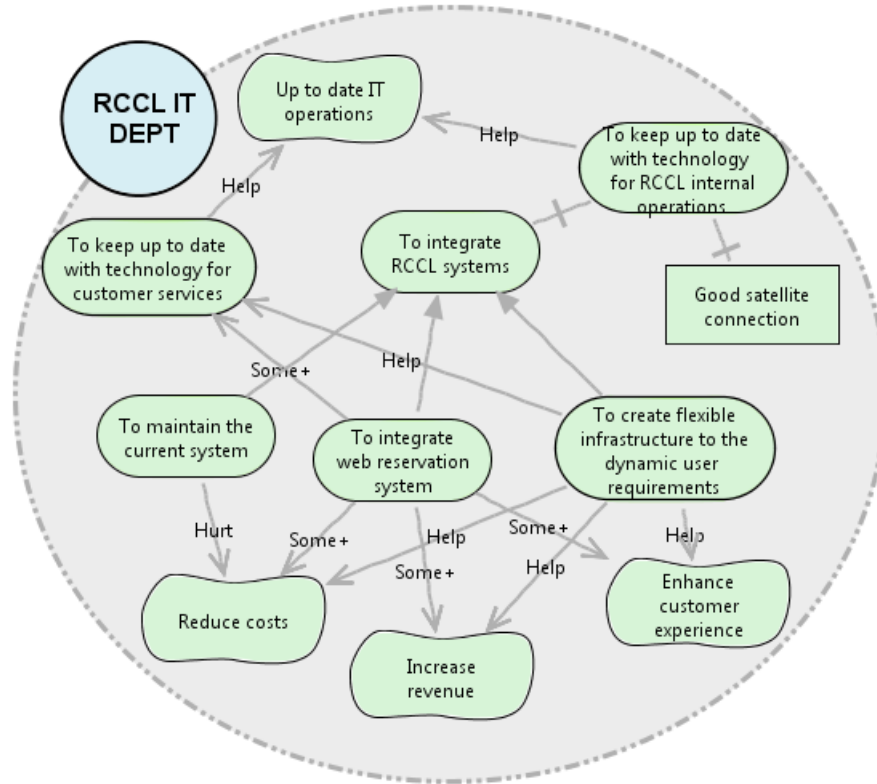

Figure 5.2: Illustration of basic I\* concepts .

internal operations”, this goal is AND-refined into one resource “Good satellite connection” and one goal “To integrate RCCL systems”.

The goal “To integrate RCCL systems” is then refined further but using OR-refinement since at this point the IT department has to implement one of the alternatives “To maintain the current system” or “To integrate the web reservation system” or “To create flexible infrastructure to the dynamic user requirement”. But RCCL has three main objectives and to the IT department are represented as soft goals “To reduce costs”, “To increase revenue” and “To enhance customer experience”. Therefore we have to determine how the IT department decision affects the general RCCL objectives. These influences are represented using the influence links (hurt, some+, some- and help). For instance the goal to “To integrate the web reservation system” positively influences the objective “To increase revenue” so its represented with a positive influence some+.

”Some+” represents an unknown positive contribution from one concept to the other while some- represents an unknown negative contribution but hurt represents a partial negative contribution while help represents a partial positive

contribution. Other influence links that are not represented in the model but are used in Istar include unknown, break and make. Unknown is contribution to a soft goal whose polarity is unknown, Make is a positive contribution strong enough to satisfice a soft goal while break is negative contribution sufficient enough to deny a soft goal [32].

### 5.1.2 Qualitative Reasoning with Goal Models

Goal graph is a pair  $\{G, R\}$  where  $G$  is a set of goals and  $R$  is set of goal relations over  $G$ .

Therefore if  $\{G, \dots, g\} \rightarrow G$  is a goal relation in  $R$  we call  $\{G, \dots, g\}$  the source goals and  $G$  the destination goal.

Label propagation algorithm[18] suggests the use of qualitative labels(PS,PD,FS,FD) where PS represents partially satisfied, PD represents partially denied, FS represents fully satisfied ,FD represents fully denied. This algorithm supports two variables on each goal (labels). While performing goal model reasoning(forward and backward) some initial goals are labeled and depending on the company objectives some questions are asked and then apply the label propagation algorithm to check if the main organization objective is satisfied.

For example we may decide to label the goal “To integrated the web reservations system” as fully satisfied. So the question is, will this strategy fulfill the IT department objectives and also satisfy the RCCL objectives. By applying the label propagation algorithm illustrated in figure 5.3, we find the three RCCL objectives receive unknown label. This is because the fully satisfied goal gives an unknown positive contribution to the soft goals and also to the IT department goal “To keep up to date with technology for customer services” hence propagating the unknown satisfaction to the main IT goal ”Up to date IT operations”.Therefore the IT department will contribute with Unknown value to the RCCL objectives. Hence this strategy does not really give very good results that can help decision makers to decide if this is the best alternative. Therefore we have to try other alternatives like to maintain the current system in figure 5.4 or to create a flexible infrastructure in figure 5.5. Figure 5.4 shows that if the goal “To maintain current system” is fully satisfied, it makes matters worse because RCCL objectives are partially denied while Figure 5.5 shows that if the goal “To create flexible infrastructure for dynamic user requirement” is fully satisfied, the results are not different from the ones got when the goal “To integrate the web reservation system” was satisfied. This demonstrates that the two goals result into some results that may need further analysis than the goal to “To maintain the current system”. Hence giving an idea to the decision maker on which alternative to focus on. So for this particular case, Murphy would focus on the two goals that result into unknown positive contribution rather than the goal that results into denial of RCCL objectives. But this kind of analysis does not give full satisfactory results



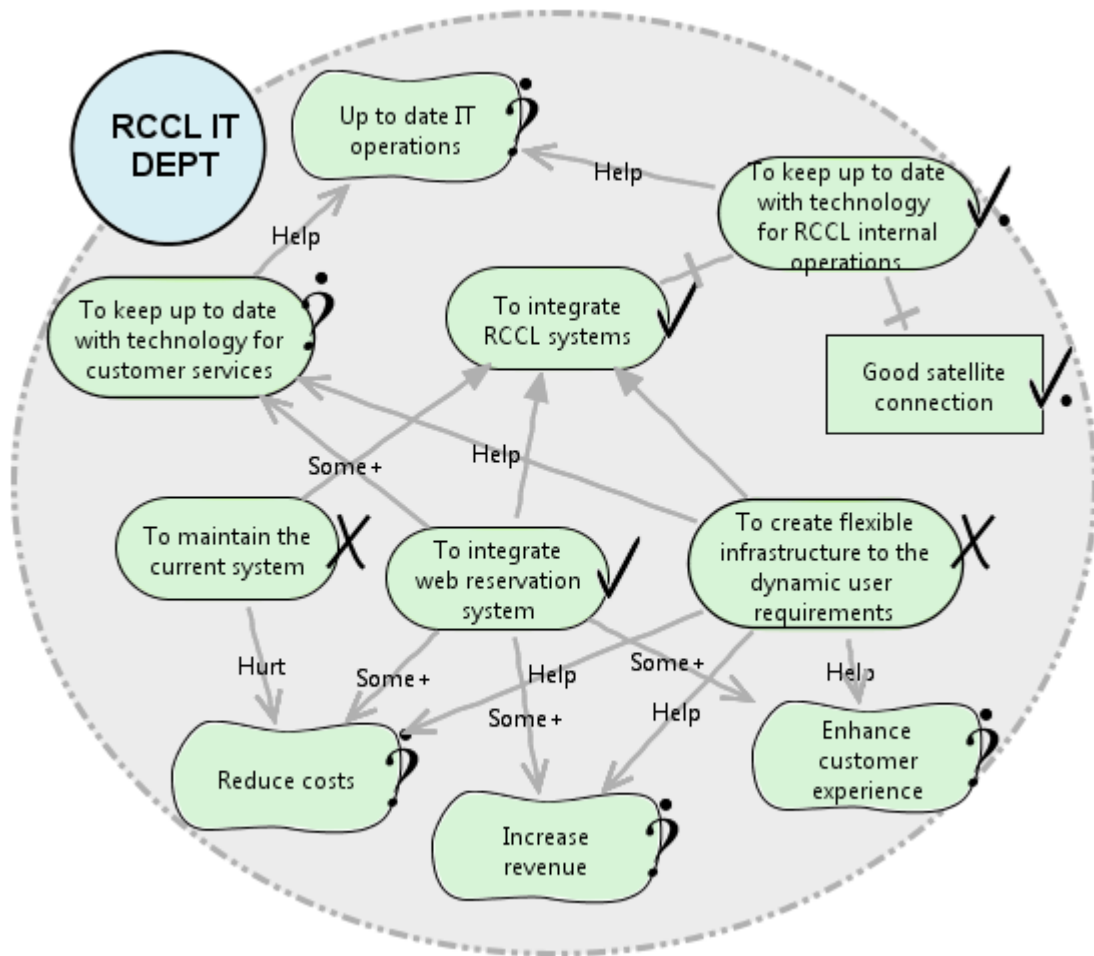

Figure 5.3: Alternative: To integrate the web reservation system

because we can see that the decision maker is still left with two alternatives to choose from, therefore on top of this goal model analysis we have to perform a model detailed analysis from which the decision maker will be able to differentiate the contribution of the goals and be able to choose one alternative. Two other analyses proposed for this work include situational analysis and use of control variables on top of the traditional goal analysis.

### Control variable analysis

This type of analysis introduces some “quantitative-like” weights on the contribution links. These can be determined from some existing information or from field experts. For example we could take the contribution of the goal “To integrate web reservation system” to be A (to reduce costs), B (To enhance customer experience) and C (To increase revenue). Likewise the goal “To create

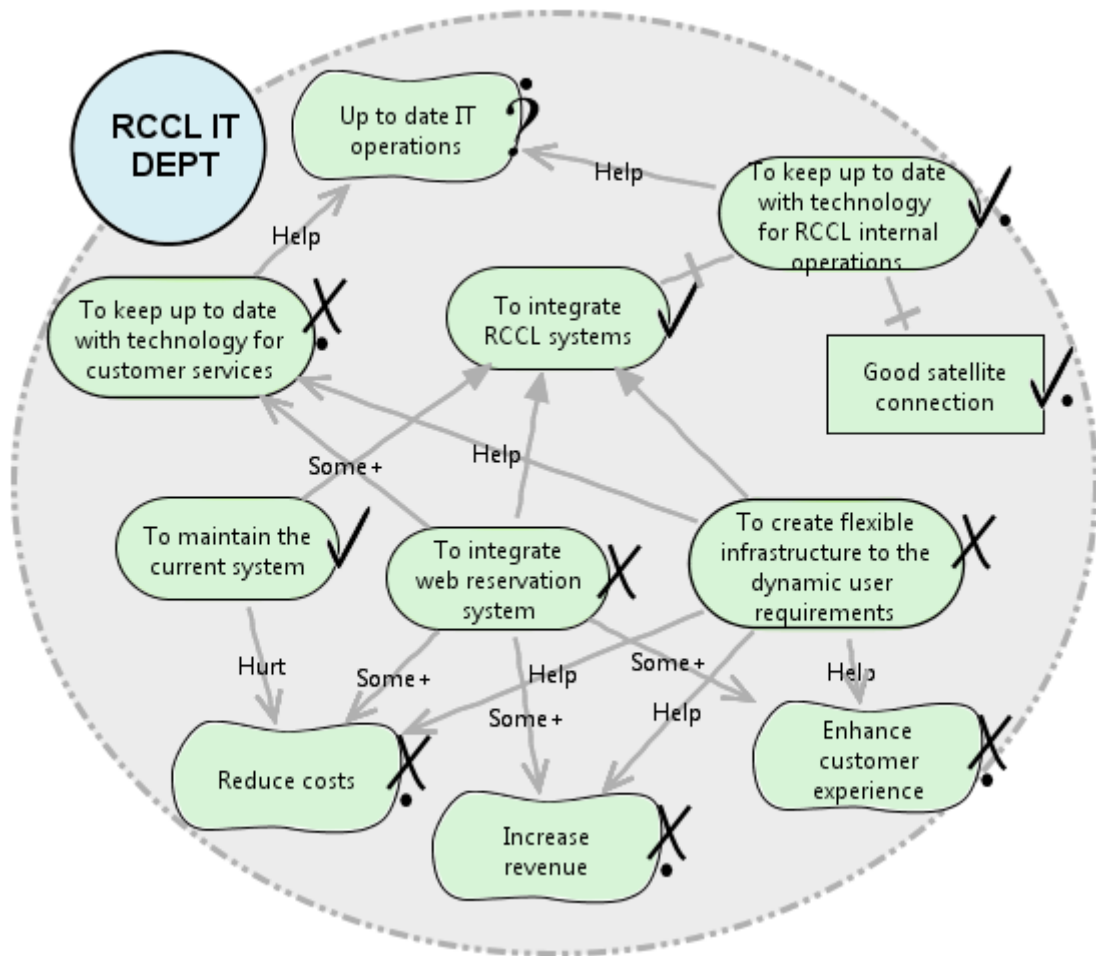

Figure 5.4: Alternative: To maintain current system

flexible infrastructure for dynamic user requirements” to have the contributions X (to reduce costs), Y (To enhance customer experience) and Z (To increase revenue). Following the provided information we could conclude for example  $(A \geq B \geq C) \leq (Z \geq X \geq Y)$  and this case we are able to estimate the contribution and compare which alternative contributes more and hence it should be implemented. But this kind of analysis need a deeper investigation on the information and contribution of the different goals therefore it will always give estimates. Hence we proposed the use of situational goal analysis which involves taking in account some internal and external factors and risk analysis that might occur if a given alternative is implemented hence introduction of Business intelligence model analysis.

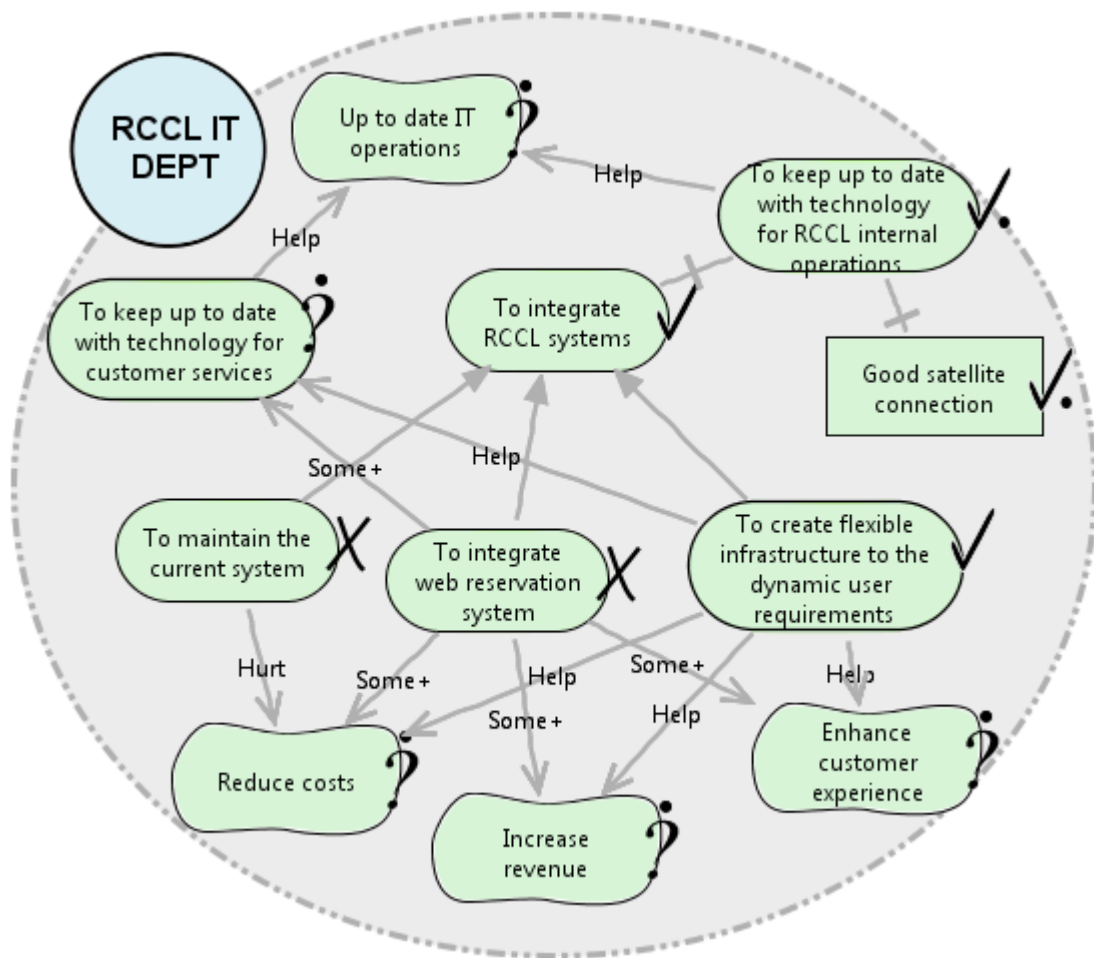

Figure 5.5: Alternative: to create a flexible infrastructure for dynamic user requirements

### Business intelligence model (BIM) and situational analysis

BIM here shows the some external situations that might influence the decision making and choosing of a given alternative. The situations are characterised into external and internal situations and these will contribute to the threats (risks), opportunities and weakness, strength of the company. While choosing an alternative, the decision maker considers the probabilities of a given situation occurring and how it affects the goals. In this kind of analysis, one is able to select best alternative that will suit the company objective in line with any other external or internal influences. The Figure 5.6 shows IT department goal “To keep up to date with Technology” AND-refined into two other sub goals. The model illustrates exactly the same goals as in the goal models in Figure 5.1 but with additional situations. The external situations represent some external forces that

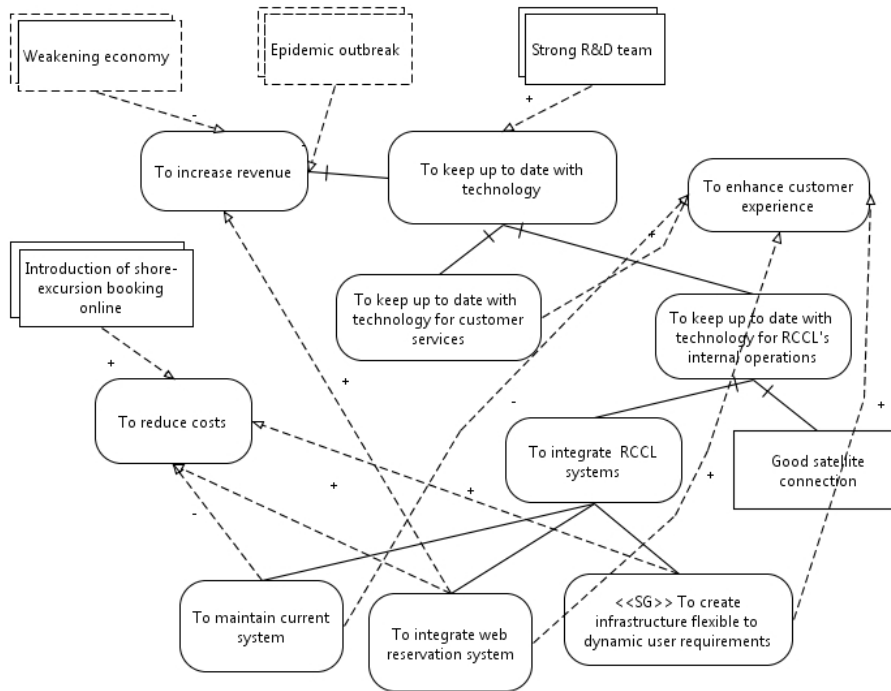

Figure 5.6: BIM situational analysis and concepts

might influence the satisfaction of a give goal. For example, weakening economy, epidemic outbreak might have a negative influence on the goal to “To increase revenue” while internal situations are some forces that might be presents within the organisation and they might influence the company goals. For example from the model the internal situation “Strong R&D” may positively influence the goal “To keep up to date with technology”. Therefore during the decision making process, the makers have to consider all these situations before selecting an alternative.

On addition to the goal modelling described in the earlier chapters, BIM strategic goal reasoning will also take in account the situations. We assign certain conditional probabilities to certain situations and then try to analyse how each alternative will be affected in line with the satisfaction of the company’s objective. For instance, what if the goal “To maintain the current system” is satisfied, what kind of situations might arise and how will they affect the RCCL objectives. We identified that there might be an increase in maintenance costs which will negatively influence the goal “To reduce costs”, “No common customer view” which will have a negative impact on the goal “To enhance customer experience”, “Low capacity systems” that will negatively impact all the company objectives as illustrated in Figure 5.7.

Therefore while making a decision and considering some of the risks that might

arise as result of implementing a given strategy, this gives the decision maker a more clear view of what to consider while selecting an alternative.

We have seen that the conceptual goal modelling works not only in RE but

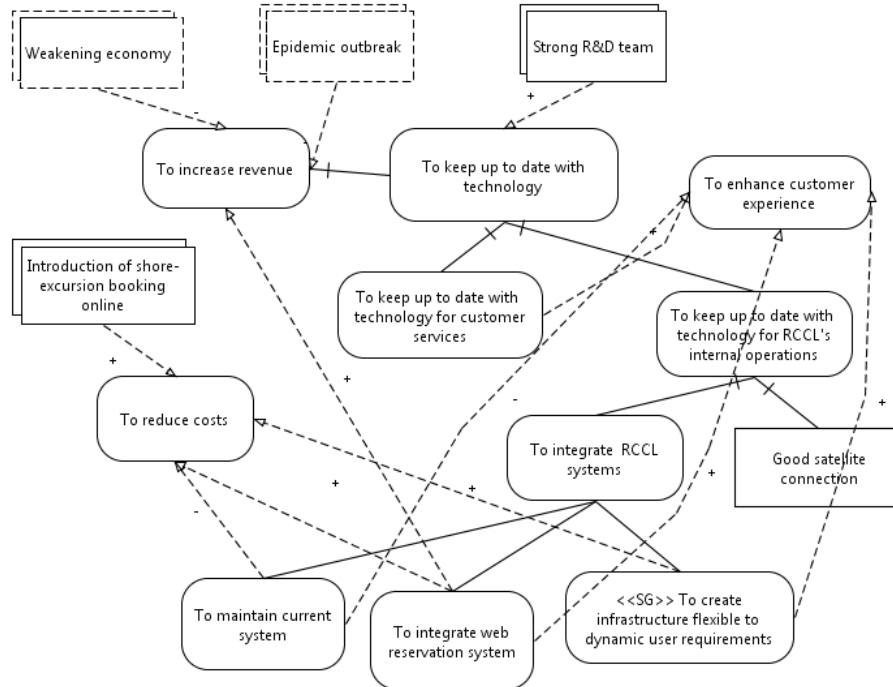

Figure 5.7: Alternative: To maintain current system

also can be used for decision making. But on top of goal models there exists the BIM that helps to perform a deeper and more resourceful analysis that gives the decision makers more knowledge and information on the alternatives before they select to implement a given alternative. Therefore a systematic decision making process we propose the use of the conceptual goal modelling reasoning technique. But in order to provide more reasons why conceptual modelling provides systematic decision making, we did a study on other decision making techniques and we considered the five force model of competition. In the next section we describe how the FFM works and then we shall compare the results with the goal models.

## 5.2 FFM

In this section, we study the Porter's five forces model of competition\*

**Traditional FFM** The Five Forces, termed as the micro environment by Porter, influence how a company serves its target market and whether it is able to turn a profit. Any change in one of the forces might mean that a company has to

\*<http://www.free-management-ebooks.com/dldebk-pdf/fme-five-forces-framework.pdf>

re-evaluate its environment and realign its business practices and strategies. It should be noted that within each industry, the effect of different forces will be different. This is why it becomes imperative to develop this model separately for every industry even if the same company is competing across different markets and industries. The five forces are divided into two main categories:

**Horizontal forces:** Threat of substitutes, threat of new entrants, competitive rivalry  
**Vertical forces:** Bargaining power of buyers and bargaining power of customers.

### **Competitive Rivalry**

One important force that Porter describes is the degree of rivalry between existing companies in the market. If there are more companies competing with each other, the resulting competitive pressure will mean that prices, profits and strategy will be driven by it. Competitive rivalry may be higher when:

- Similar sized companies operate in one market
- These companies have similar strategies
- Products on offer have similar features and offer the same benefits
- Growth in the industry is slow
- There are high barriers to exit or low barriers to entry

### **Threat of new Entrants**

The competitive threat to a company's business may not only be from existing players in the market but also from potential new entrants into the market place. If an industry is profitable, or attractive in a long term strategic manner, then it will be attractive to new companies. Unless there are barriers to entry in place, new firms may easily enter the market and change the dynamics of the industry. Therefore the firms have to determine how to increase barriers to new entrants and these may include;

- Patents and proprietary knowledge
- Access to specialized technology or infrastructure
- Economies of scale or government driven obstacles
- High initial investment needed
- High switching costs for consumers, loyal consumers
- Difficulty in accessing raw material and difficulty in accessing distribution channels

### **Threat of Substitutes**

Within the framework defined by Porter, substitute products are those that exist in another industry but may be used to fulfill the same need. The more substitutes that exist for a product, the larger the company's competitive environment and the lower the potential for profit. The threat of substitutes is affected by factors such as brand loyalty, switching costs, relative prices, as well as trends and fads.

Considering the case study, RCCL has a number of substitutes though not perfect substitutes. There are a number of leisure service companies that customers may opt to instead of RCCL. Therefore there is high intensity of threat of substitutes.

### **Bargaining Power of Buyers**

When buyers have the power to affect prices in an industry, it becomes an important factor to consider for a company. Buyers tend to have power over an industry if they are important to the company, this may be if the industry is such that buyers either buy in bulk, or can easily switch to another supplier.

RCCL offers pleasure cruises and therefore has a low intensity of buyer bp because customers are willing to pay for good services

### **Bargaining Power of Suppliers**

Suppliers provide the raw material needed to provide a good or service. This means that there is usually a need to maintain strong steady relationships with suppliers. Depending on the industry dynamics, suppliers may be in the position to dictate terms, set prices and determine availability time-lines. Supplier may enjoy more power if there are less of them. Costs of switching to an alternate are high, or there are no alternates. A supplier may also be the only provider of a certain raw material. Since in the case study literature they never mentioned about the suppliers, it's hard to estimate how intense the supplier Bp.

## **5.2.1 How FFM works**

A company or decision makers follow three basic steps when performing FFM analysis

### **1. Gather information on each force**

During the first step, the company gathers information about their industry using the five forces as a guide for classifying this information.

### **2. Analyse results and display in a diagram**

After substantial information has been gathered, the company needs to analyse how each of the identified factors affects the organisation. Every industry will have different factors affecting it differently. This makes it vital to not compare across industries or use another industry's data.

### 3. Formulate Strategy based on conclusions

The analysis of factors affecting the industry can now be translated into specific strategies to further the interests of the company.

#### **Navigating the Model Development: Before, During and After**

A company working on FFM analysis should maintain an analytical frame of mind before the process begins, during the process and after everything has been completed. Some aspects to be considered include;

##### **Before**

- To understand the goals of the analysis and expectations from it
- Understand the scope of the analysis and who the potential beneficiaries are
- To allow open and honest brainstorming session regarding these questions.

##### **During**

- To keep a focus on the future
- Do not focus on what could have been done better in the past, but focus on future improvements
- Analyse positives and negatives
- Be open to new ideas and possibilities

##### **After**

- To identify lessons learnt and how they can be used in the future
- Document positives and negatives. Identify best practices
- Understand whether the analysis had the required impact
- Follow up on implementation plans
- Record information from the analysis to be used in future decisions

## **5.3 Comparison between Goal model analysis and FFM**

We have seen that goal models provide a detailed domain understanding since it provides the decomposition of goals (objectives) and exploring of different alternatives. This provides decision makers with more information on which strategy to implement. In addition to goal decomposition, goal models provide contribution links between goals, thus an evaluator is able to determine how a given alternative (decision) hurts or facilitates the satisfaction of the company's objectives.



Goal models not only consider external situations but also internal situations. This provides more information to the decision maker and hence a more detailed decision making process which can always result into the best alternative for the organisation.

The goal model analysis (From model development to the final results), provides a step by step procedure that decision makers may follow to build a good strategy for the company. Unlike other decision making techniques, goal models provide both question and answers to strategic questions like “how” and “Why” through decomposition and contribution links.

Five forces model explains the firm’s strategy in relation to its product and market positioning, i.e. the products it makes and the market it serves. This model emphasizes the external impact on strategy development and suggests firms to evaluate those forces in an industry, which give rise to opportunities and threats. On addition, it considers the industry as a unit therefore it can only be used on one industry at a time.

## **5.4 Complementarity between FFM and Strategic goal models**

Modelling and reasoning over the Five Forces as goals provides good ground work since now the decision maker is able to evaluate the fulfilment of the company objectives in line with the FFM unlike when analysis is carried out independently using FFM where one has to brainstorm and then make conclusions.

Goal models also provide extra information that is needed for performing analysis with FFM analysis. The FFM ignores the fact that the five forces may be affected by external and internal situations not only the company strategy(goals). Therefore if combined with goal model analysis, all these are considered hence producing more reliable results

## **5.5 Systematic Decision making using Goal analysis**

The study and research indicated that goal models and analysis can be used as a decision making technique. We proposed a systematic approach to decision making using this approach.

### **Goal modeling and analysis DM<sup>†</sup> Approach**

1. Identify and Model company goals

---

<sup>†</sup>Decision making

2. Select Economic Model<sup>‡</sup>
3. Identify the relationship between the models
4. Apply uncertainty model[12]
5. Analyze and compare results

All these steps have been followed while developing the case study from chapter 4 to the conclusion in this chapter. Decision makers are able to answer most of the decision making questions and able to explore most alternatives.

## 5.6 Conclusion

The key for any model of strategic planning is effective communication among stakeholders. There are numerous iterations of goal modelling that really depend on the size and type of the organization and the people involved in the planning process. Therefore conceptual goal modeling (Strategic goal modeling) and the proposed steps provides firm foundation for decision makers to decide and select the best alternative for fulfillment the company strategic goals. This is seen from the case study results that if Murphy deploys the alternative to maintain the same budget, the company objective will be denied and if he only considers the integrating the web reservation and investing eight million on the infrastructure, the the company objective will be partially fulfilled but this comes with a number of threats or risks that in the long run might deny the company objective. But we noticed that if Murphy invests in a more flexible and dynamic systems with a much sharper budget, then not only the company objective will be partially fulfilled but also it will reduce on the risks that might hurt the company either in the long or short run. Therefore the best alternative for Murphy would be to invest a much sharp budget that would bring faster growth and development.

---

<sup>‡</sup>Economic model is a simplified framework designed to illustrate complex processes, often but not always using mathematical techniques eg. SWOT, FFM CBA etc

## Chapter 6

---

# Conclusion and Future work

---

This thesis, we have analysed and compared the existing strategic decision making techniques with the conceptual goal modelling as a decision analysis technique. Results illustrated that the existing techniques don't provide a systematic decision making process. Decision makers are not able to determine what strategy they should apply because the techniques only show how much the company has or might get in future. Focusing on FFM, we determined that it can determine the competitive position of the company in the market (industry) but is not able to show how the company or decision makers can reach the given strategic goal. In simple terms it say "Here is the company position and it competitors" but it never highlights how the company can keep or improve its position. Conceptual modelling not only provides systematic decision making but also provides a tool to visualise the company objectives and how they can be achieved/reached. Conceptual modelling considers situations that might favor or harm satisfaction of company objectives. It is noted that conceptual modelling can visualise all the other decision making techniques as illustrated in the case study with FFM goal model.

The conceptual goal models provide a practical path for strategic decision analysis in a very systematic approach. For example it's before goal model analysis, goals have to be identified, determine the contributions and decompositions between the goals and situations, assign labels and probabilities and finally determine the optimum strategy that would be help the company. Here decision makers are able to follow a step by step approach to decision making therefore by the time a decision is made it will have some concrete evidence that it will help the company to fulfill its objectives unlike the other decision making techniques described in chapter 2 of this report. Therefore Conceptual modelling can provide systematic and formal decision making.

Having determined that conceptual modelling can provide systematic decision

making, in future work could try to embed most of the already existing techniques like those described in chapter 2 so as to provide a single platform for decision making.

---

# Bibliography

---

- [1] Melanie Allen. *Analysing the Organisational Environment*. Select knowledge limited Hertfordshire, UK, 2001. [cited at p. 23]
- [2] Horkoff J Mussbacher G Peyton L Yu E Amyot D, Ghanavati S. Evaluating goal models within the goal-oriented requirement language. *International Journal Intelligent Systems*, 25(8):841–877, 2010. [cited at p. 60]
- [3] Phani Tej Adidam Anil Menon, Sundar G. Bharadwaj and Steven W. Edison. Antecedents and consequences of marketing strategy making: A model and a test. *Journal of Marketing (American Marketing Association)*, 63(2):18–40, april 1999. [cited at p. 14]
- [4] balancedscorecard.org. Balanced scorecard institute. <http://balancedscorecard.org/Resources/About-the-Balanced-Scorecard>. Accessed: 05-2015. [cited at p. 16]
- [5] Andrew Basden Birgitta Bergvall-Kareborn, Anita Mirijamdotter. Principles of ssm modelling: An examination of catwoe from a soft perspective. In *Systemic Practice and Action Research*, volume 17, Berlin, 2004. Springer. [cited at p. 24]
- [6] Greenberg D Vining A Weimer D Boardman, A. *Cost benefit analysis: Concepts and practice*. NJ: Prentice Hall, Upper Saddle River, 3 edition, 2006. [cited at p. 15]
- [7] Paul Carroll and Chunka Mui. *in Billion Dollar Lessons: What You Can Learn from the Most Inexcusable Business Failures of the Last 25 Years*. Portfolio, New York, NY, 2008. [cited at p. 8]
- [8] P. B Checkland and J Scholes. *Soft Systems Methodology in Action*. Wiley, New York, 1990a. [cited at p. 24]
- [9] Yu E Mylopoulos J Chung L, Nixon BA. Non-functional requirements in software engineering. 2000. [cited at p. 60]

- [10] R. L. Daft. *Management*. Thomson, New York, 2003. [cited at p. 14]
- [11] Lumina decision systems. Bringing clarity to difficult decisions: influence diagrams. <http://www.lumina.com/technology/influence-diagrams/>. accessed :05-2015. [cited at p. 20]
- [12] Earl T. Barr Emmanuel letier, David Stefan. Uncertainty, risk and information value in software requirements and architecture. *Proceedings of the 36th International Conference on Software Engineering*. [cited at p. 35, 72]
- [13] Lin Liu Eric Yu. *Modelling Trust in the i\* Strategic Actors Framework*. University of Toronto, Canada, 2011. [cited at p. 9]
- [14] D Fehringer. Six steps to better swots. 10(1):54–7, 2007. [cited at p. 13]
- [15] Society for Benefit-Cost Analysis. The society for benefit-cost analysis. <http://benefitcostanalysis.org/>, 2010. Accessed 05-2015. [cited at p. 15]
- [16] Valerie Massoni F. Warren Mcfarlan. Royal caribbean cruises ltd. (02163), 2003. [cited at p. 8, 29, 37, 40, 50, 51, 54]
- [17] Richard Whittington Gerry Johnson, Kevan Scholes. *Exploring Corporate Strategy: Text and Cases*. prentice hall Pearson education limited Edinburgh gate, 2008. [cited at p. 14]
- [18] Mylopoulos J. Nicchiarelli E. Sebastiani R. Giorgini, P., editor. *Reasoning with Goal Models In: Proceedings of the 21st International Conference on Conceptual Model- ing (ER'02)*, volume 3084. LNCS, Springer, Berlin, 2002. [cited at p. 31, 33, 34, 62]
- [19] Patrícia Moura e S Gopal K. Kanji. Kanji's business scorecard. *Total Quality Management and Business Excellence*, 13(1):13–27, August 2010. [cited at p. 17]
- [20] Denise Harrison. Lessons learned: Sony falls from market dominance – loss of focus causes poor decision. <http://www.cssp.com/strategicplanning/blog/lessons-learned-sony-falls-from-market-dominance-loss-of-focus-causes-poor-decision> 2013. Accessed:2015-04. [cited at p. 8]
- [21] Yu E. Horkoff, J. Finding solutions in goal models: An interactive backward reasoning approach. volume 6412 of *ER'10*, Berlin, 2010. LNCS, Springer. [cited at p. 33, 59, 60]
- [22] Yu E Horkoff J. Evaluating goal achievement in enterprise modeling—an interactive procedure and experiences. in: *Proceedings of 2nd ifip wg 8.1*

- working conference on the practice of enterprise modeling poem'09. *LNBIP*, 39:145–160, 2009. [cited at p. 60]
- [23] K. Vanhoof Houben, K. Lenie. A knowledge-based swot-analysis system as an instrument for strategic planning in small and medium sized enterprises. Elsevier Science, 3590 Diepenbeek, Belgium, 1999. [cited at p. 32]
- [24] R. A Howard. Decision analysis: Practice and promise. *Management Science*, 34(6):679–695, 1988. [cited at p. 22]
- [25] Ronald A. Howard and James E. Matheson. Influence diagrams. volume 2 of *Decision Analysis*, page 127–143. Strategic Decisions Group, September 2005. [cited at p. 19, 21]
- [26] Daniele Barone Eric Yu Daniel Amyot Alex Borgida John Mylopoulos Jennifer Horkoff, Lei Jiang. Strategic business modelling: representation and reasoning. 2012. [cited at p. 9, 30, 32, 33, 34, 38]
- [27] Eric Yu Jennifer Horkoff. Comparison and evaluation of goal-oriented satisfaction analysis techniques. 2012. [cited at p. 59]
- [28] David Jobber. *Principles and Practice of Marketing*. McGraw-Hill Education Europe, 2004. [cited at p. 7, 13, 14]
- [29] Anya Tarasova Jungkiu Choi, Dan Lovallo. Better strategy for business units: A mckinsey global survey. 2007. [cited at p. 13]
- [30] Jay Liebowitz. *business analytics; An introduction*. CRC Press Taylor and francis Group, 6000 broken sound parkway NW, December 2013. [cited at p. 7]
- [31] merriam webster. Full definition of decision. <http://www.merriam-webster.com/dictionary/decision>. Accessed April 4, 2015. [cited at p. 9]
- [32] Istar Wiki org. I\*: Online guideline. <http://istar.rwthachen.de/tikiindex.php?page=iStarQuickGuide>, 2006. Accessed: 2015-04. [cited at p. 9, 11, 28, 29, 38, 60, 62]
- [33] D. L Owen. The use of influence diagrams in structuring complex decision problems. *Readings on The Principles and Applications of Decision Analysis*, Howard, R. A. and J. E. Matheson:765–772, 1984. [cited at p. 22]
- [34] D. Geiger Pearl, J. and T. Verma. The logic of influence diagrams. *Influence Diagrams, Belief Nets and Decision Analysis*, page 67–88, 1990. [cited at p. 22]
- [35] Michael Porter. *Competitive Strategy: Techniques for Analysing Industries and Competitors*. the division of Simon & Schuster inc, New York, 1980. [cited at p. 9, 34]

- [36] QuickMBA. Strategic management (porter's five force model). <http://www.quickmba.com/strategy/porter.shtml?page=iStarQuickGuide>, 1999-2010. Accessed :April 2015. [cited at p. 10]
- [37] Jim Riley. Porter's model of industry rivalry (five forces). <http://beta.tutor2u.net/business/reference/porters-model-of-industry-rivalry-five-forces>, April 2015. [cited at p. 54]
- [38] Ray Robinson. Economic evaluation and health care: Cost-benefit analysis. 307, 1993. [cited at p. 7, 15]
- [39] Prakash P. Shenoy. A comparison of graphical techniques for decision analysis. *European Journal of Operational Research*, 78(1):1-21, October 1994. [cited at p. 22]
- [40] Roy Westbrook Terry Hill. Swot analysis: It's time for a product recall. *Long Range Planning*, 30(1):46-52, 1997. [cited at p. 14]
- [41] Axel van Lamsweerde. Goal-oriented requirements engineering: A guided tour. *Requirements Engineering, 2001. Proceedings. Fifth IEEE International Symposium on*, pages 249 - 262, 2001. [cited at p. 28]
- [42] Christian Wiermer. *Juristen als Journalisten (in German)*. GRIN Verlag. August 2007. [cited at p. 14]
- [43] B. Wilson. *Soft Systems Methodology: Conceptual Model Building and its Contribution*. wiley, Chichester, England, 2001. [cited at p. 9, 24]



## **Appendix A**

---

# **Relationship Between FFM and RCCL**

---

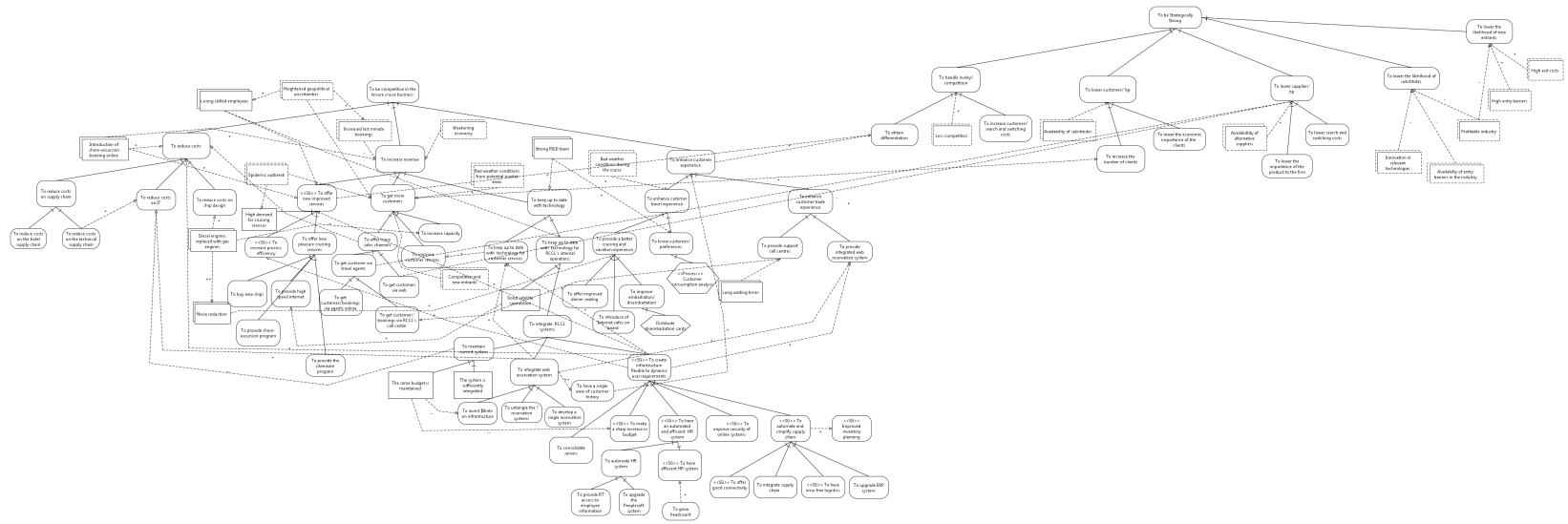

Figure A.1: Figure shows Relationship between RCCL and FFM

---

# List of Figures

---

2.1	A diagram showing Balanced Scorecard board. . . . .	18
2.2	Simple Influence Diagram . . . . .	19
2.3	A diagram showing probability tree(Decision tree). . . . .	21
3.1	Illustration of Strategic Dependency model . . . . .	28
3.2	A diagram showing Istar Relationships. . . . .	30
3.3	A diagram showing RCCL business intelligence model. . . . .	31
4.1	Figure shows the RCCL strategy (Goal model) . . . . .	40
4.2	shows "To enhance customer experience" decomposition. . . . .	41
4.3	Figure shows "To reduce cost" decomposition. . . . .	42
4.4	Figure shows "RCCL Goal Model. . . . .	45
4.5	Figure shows Level 1 Goal decomposition. . . . .	46
4.6	Figure shows Reduce costs decomposition. . . . .	48
4.7	Figure shows Reduce costs decomposition. . . . .	49
4.8	Figure shows To offer new cruising services. . . . .	50
4.9	Figure shows get more customers. . . . .	51
4.10	Figure shows To enhance customer experience Refinement . . . . .	52
4.11	Figure shows RCCL Business Intelligence model. . . . .	53
4.12	Illustration of Five forces model . . . . .	54
4.13	FFM; handle Rivalry/competition . . . . .	55
4.14	FFM:To lower customers' Bargaining power . . . . .	55
4.15	FFM:To lower suppliers' Bargaining power . . . . .	56
4.16	Illustration of Five forces refinements and External situations . . . . .	57
5.1	Illustration of dependency model . . . . .	60
5.2	Illustration of basic I* concepts . . . . .	61
5.3	Alternative: To integrate the web reservation system . . . . .	63
5.4	Alternative: To maintain current system . . . . .	64

5.5	Alternative: to create a flexible infrastructure for dynamic user requirements . . . . .	65
5.6	BIM situational analysis and concepts . . . . .	66
5.7	Alternative:To maintain current system . . . . .	67
A.1	Figure shows Relationship between RCCL and FFM . . . . .	80

---

## List of Tables

---

4.1	Contributions between RCCL and FFM goals . . . . .	58
-----	--	----